

# SAFELOG TOUCH WIRELESS

# SAFELOG TOUCH



## Installation and Operating Instruction

# SAFELOG TOUCH

## Installation and Operating Manual

<b>1. General Information and Introduction</b>	<b>6</b>
1.1 General information	6
1.2 Exclusion from liability and warranty	6
1.3 Warnings	6
<b>2. Transport and Storage</b>	<b>7</b>
2.1 Product delivery	7
2.2 Storage	7
<b>3. Product Description</b>	<b>8</b>
3.1 Equipment	9
3.2 Technical data	10
<b>4. Devices Installation</b>	<b>11</b>
4.1 Assembly	11
4.2 Electrical connection	12
4.3 SAFELOG communication	13
4.4 USB connection	14
<b>5. System Commissioning</b>	<b>15</b>
5.1 Switching on the system	16
<b>6. Operating and Programming</b>	<b>20</b>
6.1 Operating the display	21
6.1.1 Access to the status menu	23
6.1.2 Access to the main menu	25
6.1.3 Menu structure overview	27
6.2 Menu item "Info"	30
6.2.1 Ongoing messages	30
6.2.2 Consumer locations	30
6.2.3 Device info	31
6.3 Menu item "Failure"	31
6.4 Menu item "Test logbook"	32
6.4.1 Display test logbook	32
6.4.2 Result of the last F-test	32

# SAFELOG TOUCH

## Installation and Operating Manual

6.4.3	Result of the last B-test	33
6.4.4	Manual documentation	33
6.4.5	Export test logbook	34
6.5	Menu item "Service"	34
6.6	Menu item "Test menu"	34
6.6.1	Manual function test	35
6.6.2	Manual operating duration test	37
6.6.3	Function test settings	38
6.6.4	Settings - operating duration test	39
6.7	Menu item "Settings"	39
6.7.1	Bus circuits	40
6.7.2	Consumer data	42
6.7.3	Devices location of SAFELOG	51
6.7.4	Timers	51
6.7.5	Inputs/outputs	52
6.7.6	Actuating consumes (NMM/MM)	55
6.8	Menu item "System"	56
6.8.1	Changing date and time	57
6.8.2	Devices – Options	57
6.8.3	Network settings	58
6.8.4	Changing the language	61
6.8.5	Changing system data ("Import/Export")	61
6.8.6	Configuration of e-mail settings	64
6.8.7	Change password	66
<b>7.</b>	<b>Web Visualisation</b>	<b>67</b>
7.1	Overall view	68
7.2	Detailed view	69
7.2.1	Elements of the detailed view	70
7.2.2	Status display	71
7.2.3	Main menu	72
7.2.4	Submenu	73
7.2.5	Info	74

# SAFELOG TOUCH

## Installation and Operating Manual

7.2.6	Failure	74
7.2.7	Test logbook	75
7.2.8	Test menu	77
7.2.9	Settings	79
7.2.10	System	85
7.2.11	Building visualisation	88
<b>8.1</b>	<b>Maintenance of the System</b>	<b>93</b>
8.1	Initial inspections of the installation	93
8.2	Recurrent inspections	93
8.2.1	Daily inspections	93
8.2.2	Weekly inspections	94
8.2.3	Monthly inspections	94
8.2.4	Yearly inspections	94
8.2.5	Inspections every three years	95
8.3	Protocols on recurrent inspections (Test protocols)	95
<b>9.1</b>	<b>Appendix</b>	<b>96</b>
9.1	Fault notifications and failure correction	96
9.1.1	Missing consumers	96
9.1.2	Failure messages	98
9.1.3	Communication failure	99
9.1.4	Other failures	100
9.1.5	SAFELOG device is off	100
9.2	Replacing consumers	101
<b>10.1</b>	<b>Connection and Programming of the Switching inputs</b>	<b>102</b>
10.1	Switching consumers via additional modules	102
10.2	Switching consumers without additional modules	103
10.3	Connection of status panel (MFT4)	105

### LIST OF ABBREVIATIONS

<b>Consumers</b>	Luminaires, line couplers, repeaters, conversion kits and emergency luminaire converters
<b>MM</b>	Maintained mode. The luminaire of the consumer is constantly activated
<b>NMM</b>	Non maintained mode. The luminaire of the connected consumer only lights up in the emergency mode
<b>SL</b>	SAFELOG Line (wire-connected Bus system RS485)
<b>SWX</b>	SAFELOG Wireless (Wireless Bus system SRD 868MHz)
<b>F-Test</b>	Function test in acc. with DIN VDE 0108 and DIN EN 62034
<b>B-Test</b>	Battery time test in acc. with DIN VDE 0108 and DIN EN 62034

# 1. General Information and Introduction

## 1.1 General information

Only those with appropriate training or electricians are permitted to install, operate and service the system. Please thoroughly read through the instruction before installing and commissioning the system. Only in this way is safe and correct handling ensured. Any work on the devices is only to be carried out in a de-energised state. The applicable safety and accident prevention regulations are to be kept to.

The instructions refer to our latest model: the SAFELOG TOUCH WIRELESS. Do bear in mind when commissioning the SAFELOG TOUCH that no wireless functions are in place and that they cannot be retrofitted at a later date.

## 1.2 Exclusion from liability and warranty

We assume no warranty or liability for damage or sequential damage brought about by the following:

- Incorrectly implemented installation or operation of the system
- Accessing the SAFELOG device
- Operating products and/or components not suited for the emergency lighting
- Non-adherence to regulations for fail-safe system operations
- System operated by those with no due authorisation (incorrect operation)

## 1.3 Warnings

The power supply must be isolated to de-energize the system. Only trained electricians are to undertake work when the system is energized.

In replacing parts of the device only those of the same type and with the same characteristics or manufacturer-approved spare types are to be used. Operating incorrect or faulty parts can result in non-functioning safety lighting.

## 2. Transport and Storage

### 2.1 Product delivery

On receipt of the device, check that all its contents are on hand and that there is no obvious damage. Report any damage immediately to the forwarder and bear in mind the following:

- Leave the product and its packing as it is after opening.
- Report the damage to the forwarder.
- Then contact the seller.
- After examination by the forwarder and receipt of damage confirmation, you can return the defective product to the seller.

### 2.2 Storage

Do not store the device outdoors up to mounting - it must be kept where it is dry and dust-free. The temperature there is to be between 0°C and + 35°C.

## 3. Product Description

The SAFELOG system is for monitoring and controlling safety and exit sign luminaires as well as other SAFELOG-compatible consumers.

The SAFELOG TOUCH and the SAFELOG TOUCH WIRELESS have an integrated test log-book according to DIN VDE 0108 10/89, which is saved in the system, but can alternatively be stored on a USB stick with a FAT32 file system.

There are two different ways available between the SAFELOG device and the consumers:

### 1. SAFELOG Wireless (SWX)

### 2. SAFELOG Line (SL)

The SAFELOG Wireless system does not undertake communication between the consumers through an additional data cable but is wireless -communicated. The consumers build up a "mesh network" and use it for communication purposes.

The cable-connected SAFELOG Line system operates on the basis of the RS485 Bus. The connected consumers communicate via the bus with the line coupler / the SAFELOG main control unit.

Consumers comprise self-contained luminaires, line couplers, repeaters, conversion sets and emergency luminaire converters. All consumers must be compatible with SAFELOG Line or SAFELOG Wireless (SWX). Non-system consumers cannot be connected to the monitoring system.

A multi-touch-enabled 5" colour display showing the operating states of the consumers controls all the connected self-contained luminaires.

The SAFELOG main control unit has a network connection permitting the state of the devices to be accessed using the installed web server.

There is still the option of remote-controlling the main control unit via the web server and saving building plans.

## 3.1 Equipment

### General

- 5" multi-touch-capable colour display including a USB port for connecting external storage, a USB printer, a keyboard or a mouse
- State display of the luminaires through icons and in plain text
- Automatic commissioning incl. luminaire search, no manual addressing needed of the luminaires
- Entry at will of luminaire destination names each of a max. 30 characters
- RJ45 network connection with TCP/IP protocol
- Integrated web server incl. web visualisation for system monitoring with web control and web building visualisation
- Freely adjustable e-mail messaging to mailing list /messages
- Automatic function and operation duration test (at liberty to choose the time)
- Electronic test logbook saves all the events at the main control unit for at least 4 years/ evaluation and analysis of the test logbook result by way of web control
- 48 readily programmable groups or group assignment
- 24 timers readily programmable
- Luminaires in maintained lighting / non-maintained lighting are switchable (All / per bus line / per group / luminaire)
- Combination of wireless and cable-connected, bus-monitored luminaires possible
- Password-protected access across two levels (user / installer)

## 3.2 Technical data

Power supply	1/N/PE AC 50 Hz 230 V
Power consumption	12 W
Connecting terminals - mains	1.5 mm <sup>2</sup> up to 2.5 mm <sup>2</sup>
Bus connections	2 x RS485 (5V level) / polarity protection
Switching outputs	3 x change-over contacts (programmable, potential-free)
Switching inputs	2 x optocouplers (programmable, 24V – 230V AC / DC)
Extra power supply	24V / 40 mA for external modules
Ambient temperature	0 °C to 35 °C
Safety class	II
Protection class (housing)	IP65
Dimensions (W × H × D)	240 x 185 x 112 mm

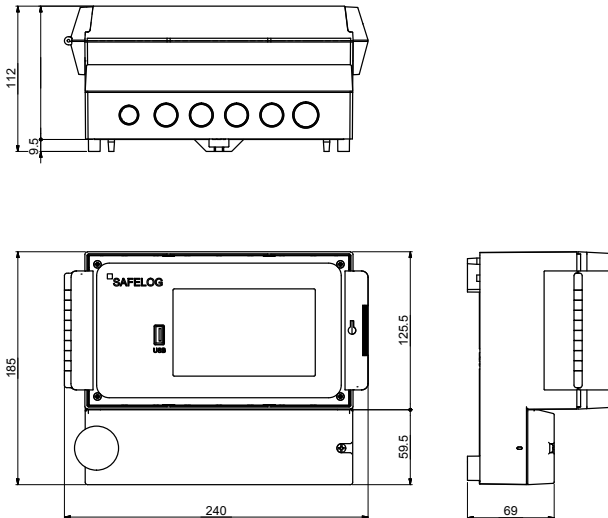

Fig. 1: Dimensional drawing SAFELOG

## 4. Devices Installation

### 4.1 Assembly

Remove the packing from the device and place down on its back. Unscrew the two screws of the cover and remove the lower cover.

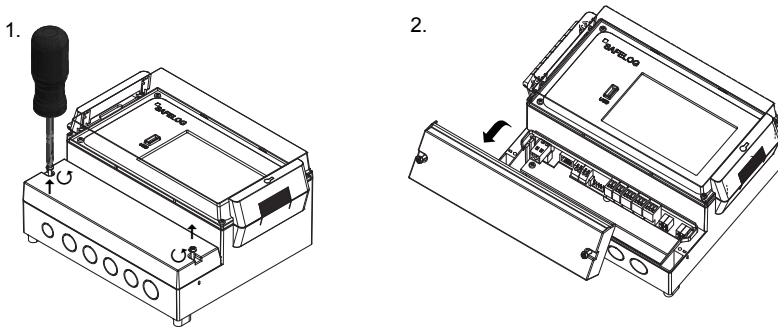

Fig. 2: Opening the housing

For the mounting, take on the dimensions of the rear mounting plate of the SAFELOG device. Please note that the wall together with the screws and plugs used need to support the weight of the device.

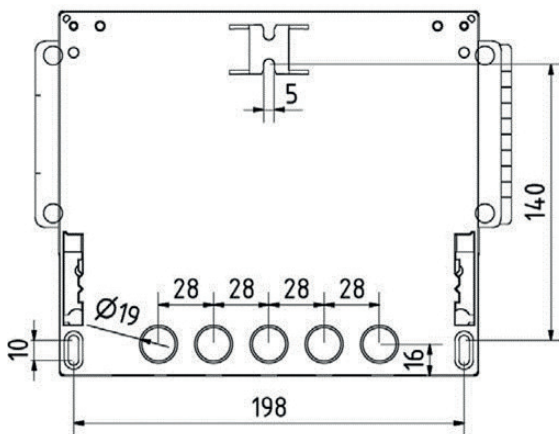

Fig. 3: Mounting plate

To prevent unauthorised accessing, the SAFELOG device can be provided with a lock at the control panel window. A socket wrench is in the SAFELOG device scope of delivery.

## 4.2 Electrical connection



Fig. 4: View of connecting terminals

### Allocation of terminals:

Mains/Line	Mains connection (1.5 – 2.5 mm <sup>2</sup> )
LAN	Network connection
Ext	Connection for modules
+24 V	24 V / 40 mA supply voltage for external modules
IN1/IN2	Programmable inputs (24 V to 230V AC)
OUT1, OUT2, OUT3	Programmable, potential-free outputs (change-over contacts max. 2A 250 V AC)
1 / 2	Connection for bus line (0.5 – 0.8 mm <sup>2</sup> )

For connecting the lines, only the supplied connecting terminals are to be used.

**If you use other terminals or use the terminals for voltage actuation, no warranty is assumed for the SAFELOG device.**

### 4.3 SAFELOG communication

During the installation of the BUS, observe the following:

- The BUS lines (A / B) should be colour-coded (e.g., white/yellow) for easy laying.
- Do not connect any external voltage to the BUS. The connection of external voltages to the BUS can destroy all consumers!
- The BUS line (A / B) must be wired together in parallel.
- The system has two bus circuits; distribution of the consumers per common line need not be identical.
- Note that each circuit has a physical limit of 250 consumers.
- The BUS line should be handled like a low-voltage line and not be laid with mains-conducting lines.
- Preferably use a shielded cable in order to suppress interference with the BUS lines in the best possible way.
- If line couplers are connected in series, i.e. if additional levels are added, then the maximum number of levels is 4!

For further information, turn to the installation and planning instructions for SAFELOG systems.

**Wireless systems are always to be commissioned in the following sequence:**

1. Installation and permanent setting up of the power supply at all consumers.
2. With Item 1. fully dealt with, wait until the radio network has completely set itself up.
3. Incorporating and importing the consumers into the SAFELOG main control unit.
4. Examination of the tracked consumers as to completeness.

## 4.4 USB connection

The SAFELOG device has a USB connection at the front next to the display.

The connection can be used to back up the data, configuration and test logbook. You can, as an option, also connect up a keyboard or mouse.

USB sticks need to be of the FAT323 format for use at the SAFELOG device.

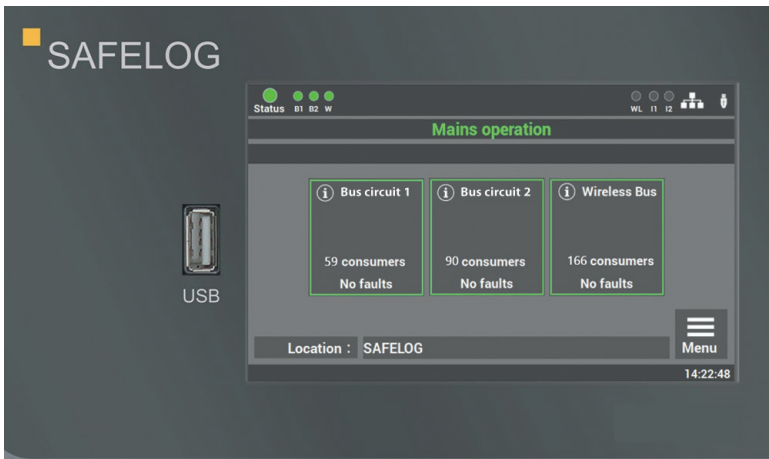

Fig. 5: USB connection at the display

## 5. System Commissioning

Only qualified and trained electricians are allowed to commission the system. The manual takes you through system commissioning step-by-step. During the commissioning, the SAFELOG device goes through a fixed routine which cannot be aborted by the display. The routine re-starts and entries need to be repeated should the charging current fail during the commissioning.

**Once terminated the commissioning can only be re-activated via the "Reset to factory settings" function.**

### Check the following before switching on:

- All electrical connections at the SAFELOG device
- The device No. on the rating plate of the system (see Fig. 6)  
(this is needed when commissioning)

<b>Device number:</b>	<b>XXXX XXXX</b>
Device name:	SAFELOG TOUCH
Serial number:	00A8007011110006
Supply voltage:	230V 50Hz
Connected load:	12W
Protection class:	IP65
Safety class:	I
Temperature range:	0°C to 35°C
Manufactured:	12/99







Fig. 6: Device number on rating plate

## 5.1 Switching on the system

Please keep to the following order when switching on the system:

1. Installation all consumers and the main control unit is completed
2. Insert external fuse for the SAFELOG device

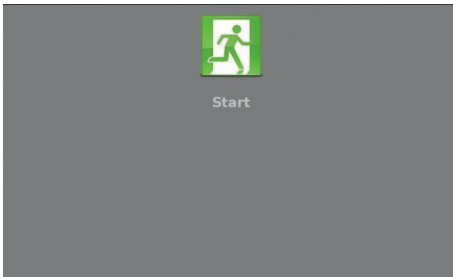

Fig. 7: Start

**Step 1:** Switching on the SAFELOG device for the first time results in a sequence routine being started for the commissioning. At a number of points, this routine requests you, as the user, to enter certain values. All entries are system-confirmed.

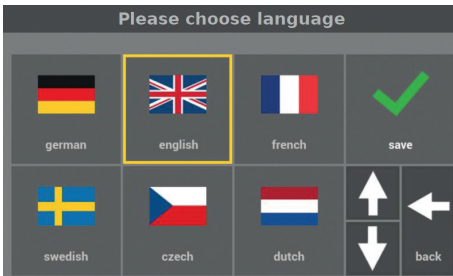

Fig. 8: Language choice

**Step 2:** You can choose the language of the device here. The choice can also be subsequently changed in the menu.



Fig. 9: Read through instructions

**Step 3:** You are called upon to read through the system instructions to ensure correct installation.



Fig. 10: Entering the device number

**Step 4:** Take up the device number from the rating plate (see Fig 6) when you are requested to enter this number and confirm with "Enter". The number is precisely 8 digits in length.



Fig. 11: Wireless network setup

**Step 5:** The wireless network setup is started with "next".

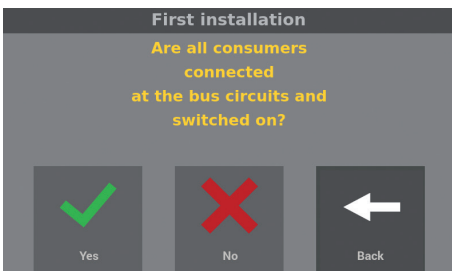

Fig. 12: Confirmation of the connected consumers

**Step 6:** You must then confirm at the device that all consumers at the BUS and mains are connected and that the LED status of the consumers is "green".

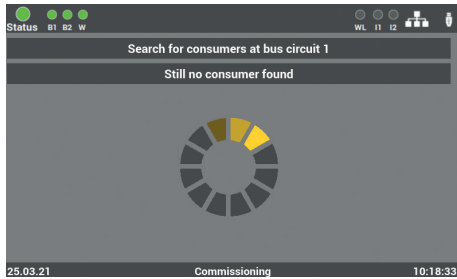

Fig. 13: Automatic consumer search

Following confirmation, the device searches for all the bus-connected consumers.

This can take a few minutes.



Fig. 14: Start "INVITE"

The as-delivered consumers are not assigned to any ID network. In order to assign the consumers to a main control unit, the main control unit transmits their ID network (INVITE function). All consumers adopting this ID network are allocated to the main control unit.

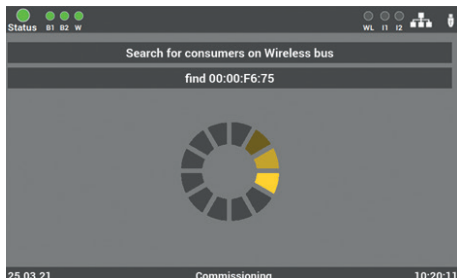

Fig. 15: Search for wireless consumers

Once the wireless network is set up, the device searches for all active wireless consumers and adds them to the Wireless bus.

This can take a few minutes.

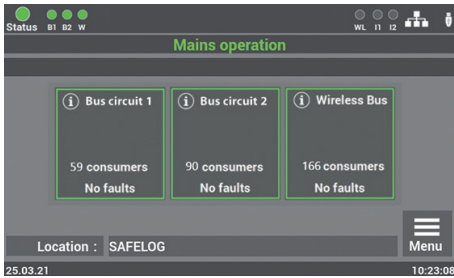

Fig. 16: Start mask

Commissioning of the system is thus concluded.

**For further operations and programming, please read through Chapter 6 of the operating manual.**

## 6. Operating and Programming

The SAFELOG device is such that a touch display is used for operating and programming. As an alternative, inputs can follow by way of a USB mouse and/or USB keyboard.

Under various menu items you can correct the settings of the data with the arrow keys. Note that when pressing the keys just once the data changes in single steps. Pressing the key for longer results in the data being rapidly run through.

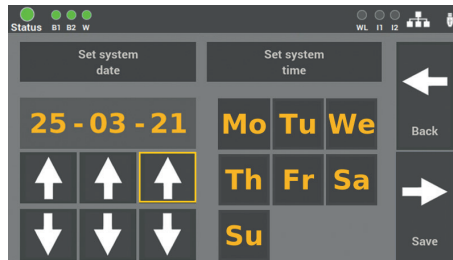

Fig. 17: Mask example of arrow keys

A yellow surround is displayed around the activated function to signal which function in the SAFELOG device is activated.

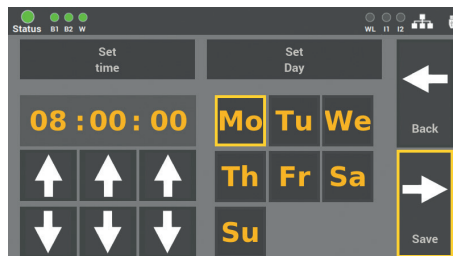

Fig. 18: Mask example of an active function

**The important thing is that all changes are saved!**

## 6.1 Operating the display

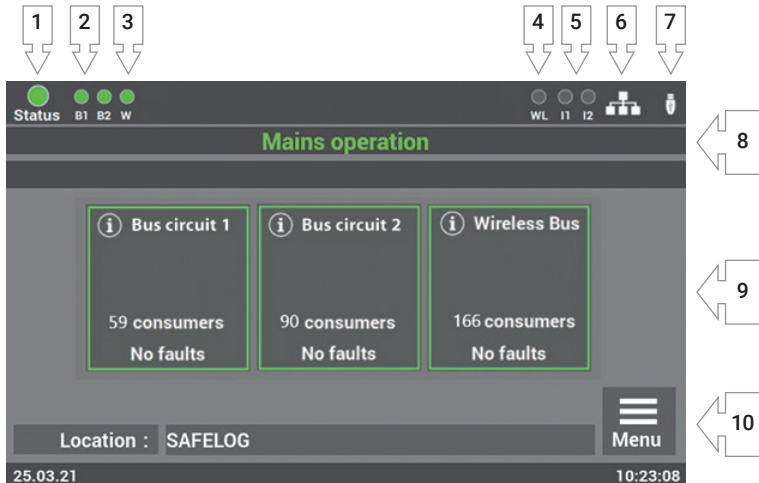







Fig. 19: Display operating

1. Display: System status
2. Display: Status of the bus circuits
3. Display: Status of the Wireless Bus
4. Display: Wireless data transfer
5. Display: Input - Control inputs
6. Display: Network connection - when connected
7. Display: USB stick - when connected
8. Display: System state (operation/battery/failure)
9. Display and access to status menu
10. Access to main menu

1. The system status display incorporates the following states:



-  **Green** System with no faults
-  **Yellow** System in the battery operation
-  **Red** System with fault/failure message

2. The display for the bus circuit has 2 messages:

-  **Green** Consumers in the bus circuit have **no** failures
-  **Red** Consumers in the bus circuit **with** failures



Failures in the load circuit are not displayed as failures in the system status. In its message the display differentiates between luminaire failure and system failure.

3. The wireless circuit display has 2 messages:

-  **Green** Consumers in the bus circuit have **no** failures
-  **Red** Consumers in the bus circuit **with** failures

Failures in the load circuit are not displayed as failures in the system status. In its message the display differentiates between luminaire failure and system failure.

4. The wireless data transmission display has 2 messages:

-  **Yellow** Receipt of data
-  **Blue** Transmitting data

5. Display I1 – I2 shows the allocation of the control inputs. As soon as a signal is there at the inputs, the corresponding LED lights up in green.

6. The symbol for the network connection  appears when there is a connection to the network.

7. The symbol for the USB stick  appears when a USD stick is inserted at the front display. The USB stick needs to be formatted with FAT32.

8. The display indicates the state of the main control unit and the connected consumers.

9. The bus circuits are shown as tiles in the display. They bring you to the status menu of the system. Assigning the tiles by colour is a help in operating the system on a daily basis. The following states are:

- **Green** All consumers in the bus circuit are OK
- **Yellow** One or several consumers in the bus circuit in the battery operation
- **Red** One or several consumers in the bus circuit are reporting a fault

10. Access to the SAFELOG device main menu.

### 6.1.1 Access to the status menu

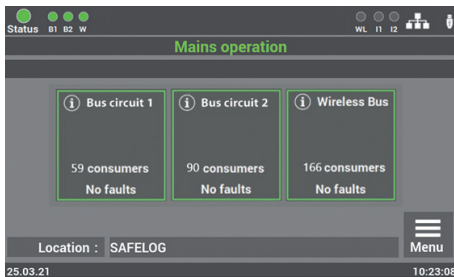

Fig. 20: Accessing bus circuits

The status menu opens when a "bus circuit: X" key is opened on the main display screen.

The menu is for information only. The data cannot be changed here.

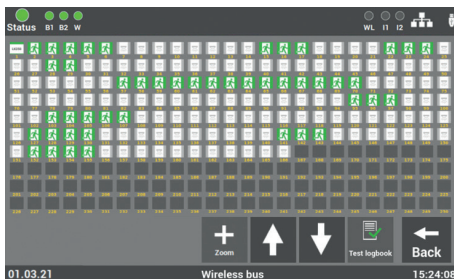

Fig. 21: Overview of the consumers

By selecting a bus circuit, an overview is opened in which all the consumers of the selected circuit are shown. There are three different views of the circuits. In the first view, all the consumers can be seen at a glance.

The colour of the icons in the illustration indicates the state of the consumers.

Consumers	On	Off	In the battery operation	In the case of a fault
Exit sign luminaires				
Escape route luminaire				
NVG				
Repeater				
line coupler				

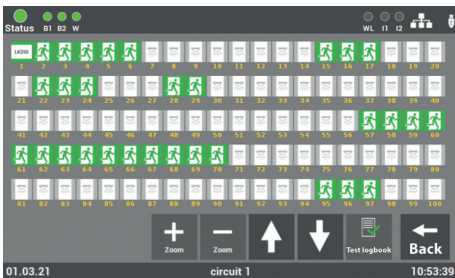

Fig. 22: Bus circuit overview - centre view

Press the "+/-" zoom keys to enlarge the view or reduced it in size. Moreover, the view can be adjusted by selecting the required consumer. Scrolling through the view can be done with the arrow keys. The "Test logbook" function indicates the entries of the selected bus circuit here.



Fig. 23: Overview - Selection of consumers

In the "Details" view, the consumer required can be opened from the direct selection.

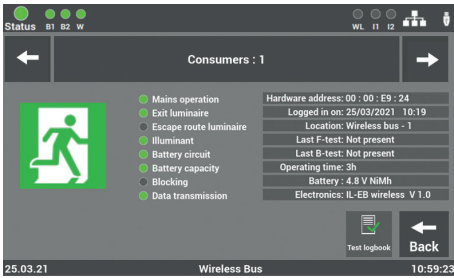

Fig. 24: Status of consumers

The detailed view of a consumer provides you with all vital information on its state.

The arrows "←/→" allow you to scroll through the consumers.

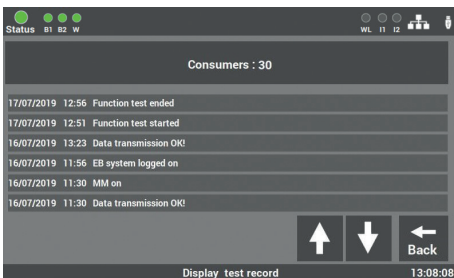

Fig. 25: Test logbook of consumers

Only the entries of the consumer as selected in the test logbook are shown.

## 6.1.2 Access to the main menu

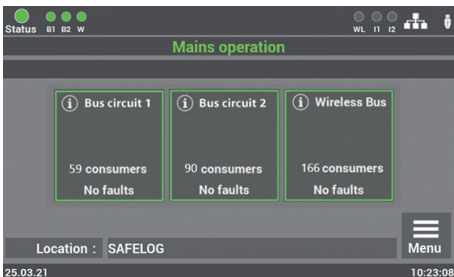

Fig. 26: Menu Access

**Step 1:** The main menu opens when the "Menu" key on the main display screen is activated. To protect the SAFELOG device from unauthorised interventions, the main menu is password-protected.

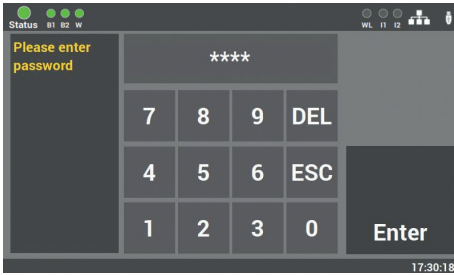

Fig. 27: Menu Enter password

**Step 2:** In the delivery status, the password for the system is: "0000". Entering the code is not necessary. You automatically get into the main menu by pressing the "Enter" key.

You can create your own password in the menu at a later stage.

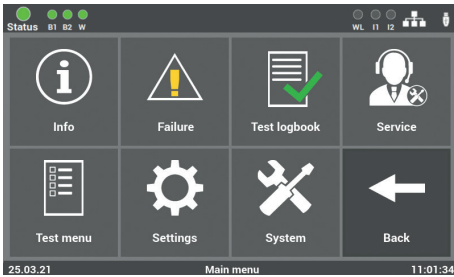

Fig. 28: Main menu mask

**Step 3:** After entering the password, the main menu of the SAFELOG device opens up. From this menu you can get to all the other sub-items.

## 6.1.3 Menu structure overview

### 6.1 Menu



#### 6.2 Menu item "Info"

- 6.2.1 Ongoing messages
- 6.2.2 Consumer locations
- 6.2.3 Devices info



#### 6.3 Menu item "Failure"



#### 6.4 Menu item "Test logbook"

- 6.4.1 Display test logbook
- 6.4.2 Result of the last F-test
- 6.4.3 Result of the last operating duration test
- 6.4.4 Manual documentation
- 6.4.5 Export test logbook



#### 6.5 Menu item "Service"



#### 6.6 Menu item "Test menu"

- 6.6.1 Manual function test
  - 6.6.1.1 Function test by bus circuits
  - 6.6.1.2 Function test - wireless circuit
  - 6.6.1.3 Function test - all consumers
  - 6.6.1.4 Manual function test by groups
- 6.6.2 Manual operating duration test
  - 6.6.2.1 Operating duration test - bus circuits
  - 6.6.2.2 Operating duration test - wireless circuit
  - 6.6.2.3 Operating duration test - all consumers
  - 6.6.2.4 Operating duration test - groups
- 6.6.3 Settings - function test
- 6.6.4 Settings - operating duration test



## 6.7 Menu item "Settings"

### 6.7.1 Bus circuits

- 6.7.1.1 Search in bus circuits
- 6.7.1.2 Search in wireless bus
- 6.7.1.3 Bus circuits - locations



### 6.7.2 Consumer data

- 6.7.2.1 Consumers in the bus circuit
  - 6.7.2.1.1 Clearing all consumers in the bus circuit
  - 6.7.2.1.2 Change consumers in the bus circuit
  - 6.7.2.1.3 Selection of the function
  - 6.7.2.1.4 Entry of consumer locations
  - 6.7.2.1.5 Clearing consumers
  - 6.7.2.1.6 Finding consumers (nod)
  - 6.7.2.1.7 Actuating consumers
  - 6.7.2.1.8 Group housing
  - 6.7.2.1.9 Starting function test of individual consumers
  - 6.7.2.1.10 Change consumer type (Safety / exit luminaires)
- 6.7.2.2 Import and export of consumer location

### 6.7.3 Devices location of SAFELOG

### 6.7.4 Timers

- 6.7.4.1 Programming sequence

### 6.7.5 Inputs/outputs

- 6.7.5.1 Control inputs – Selection
- 6.7.5.2 Relay outputs – Selection

### 6.7.6 Actuating consumes (NMM/MM)

- 6.7.6.1 Maintained mode – Actuate MM
- 6.7.6.2 Non-maintained mode - Actuate NMM



## **6.8 Menu item "System"**

**6.8.1 Changing date and time**

**6.8.2 Devices - Options**

**6.8.3 Network settings**

6.8.3.1 DHCP address

6.8.3.2 Change static IP address

6.8.3.3 Change gateway address

6.8.3.4 Subnet

6.8.3.5 Primary DNS

6.8.3.6 Secondary DNS

**6.8.4 Changing the language**

**6.8.5 Changing system data („Import/Export“)**

6.8.5.1 Reset to delivery status

6.8.5.2 Secure data

6.8.5.3 Data renew

6.8.5.4 Update activate

6.8.5.5 System start

**6.8.6 Configuration of e-mail settings**

6.8.6.1 Configure recipient address

6.8.6.2 Settings for e-mail dispatching

**6.8.7 Change password**

## 6.2 Menu item "Info"

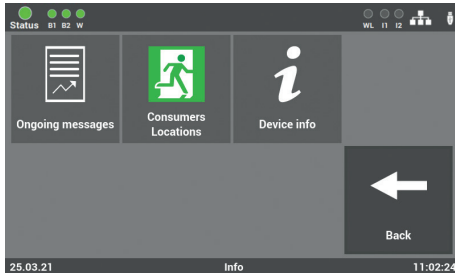

Fig. 29: Menu item "Info"

A general overview is provided in this menu item of the SAFELOG device and the connected consumers. Here you can see all the ongoing system messages, the mounting locations of the consumers and you are provided with an overview of the SAFELOG device status. The menu item is only for information purposes. No data can be changed here.

### 6.2.1 Ongoing messages



Fig. 30: Mask "Ongoing messages"

A general overview is provided in this mask of the state of the entire emergency lighting system at the main control unit.

### 6.2.2 Consumer locations

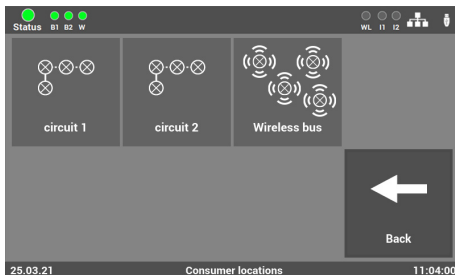

Fig. 31: Mask "Circuit locations"

**Mask 1:** This is where you select the required bus circuit so as to see where the consumers of the BUS circuit are mounted.

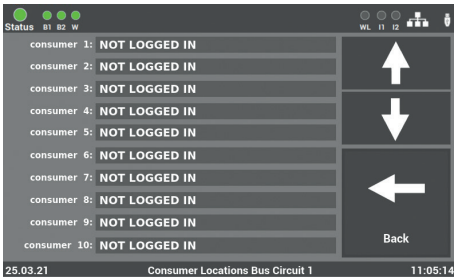

Fig. 32: "Locations" Detailed view

**Mask 2:** In this overview, you can see where the consumers for each bus circuit are mounted.

## 6.2.3 Device info

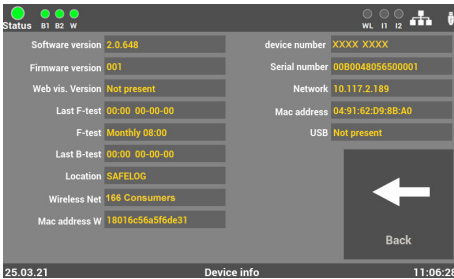

Fig. 33: "Devices info"

All important data and state of the SAFELOG device can be seen in this mask.

## 6.3 Menu item "Failure"

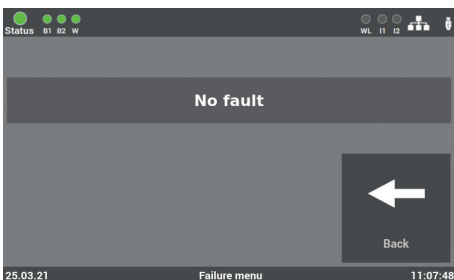

Fig. 34: Menu item "Failure"

This view displays all the upcoming failure messages and/or faults in plain text.

## 6.4 Menu item "Test logbook"

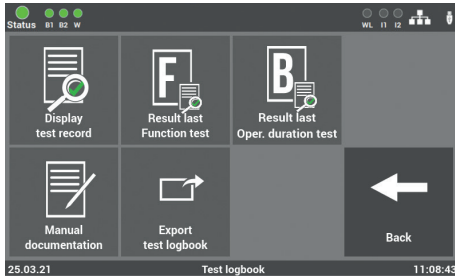

Fig. 35: Menu item "Test logbook"

In this mask you obtain an insight into all the logged recordings of the system. Here you can document all the work carried out and export all data on a USB stick.

### 6.4.1 Display test logbook

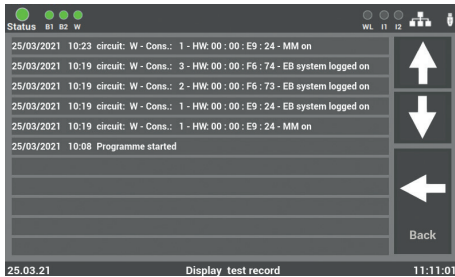

Fig. 36: "Display test logbook"

All entries and messages are documented in this mask. Operating is one with the arrow keys. Press the "Back" key to get back to the "Test logbook" menu item.

### 6.4.2 Result of the last F-test

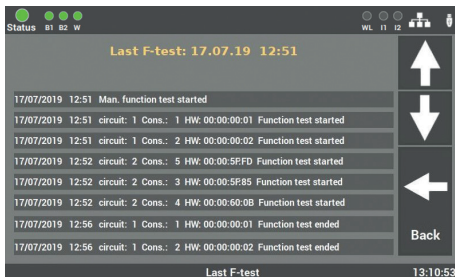

Fig. 37: "Result of last F-test"

This view provides a compact overview of the result of the last F-test.

### 6.4.3 Result of the last B-test

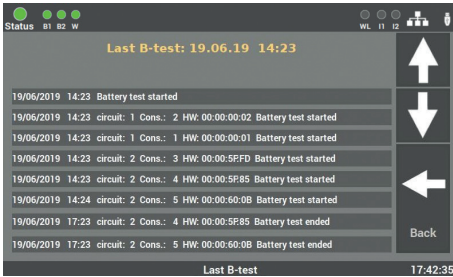

Fig. 38: "Result of last operating duration test"

The data of the last operating duration test is shown here.

### 6.4.4 Manual documentation

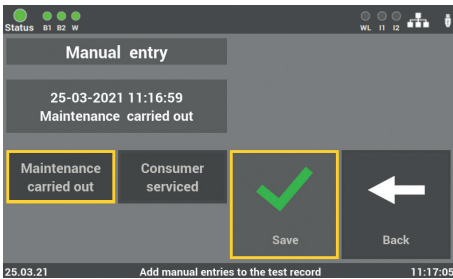

Fig. 39: Mask "Manual documentation – System maintenance"

The SAFELOG device enables all work carried out on the device to be documented in the test logbook: "Maintenance carried out" or "Consumer serviced".

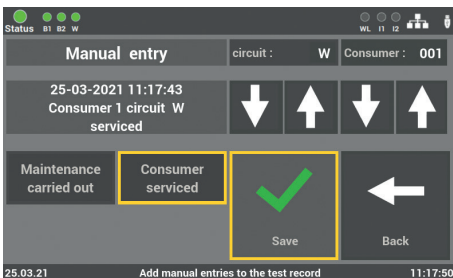

Fig. 40: Mask "Manual documentation – Maintenance of consumers"

The "Consumer serviced" mask allows you to select the bus circuit and consumer.

The work entered is documented in the test logbook.

## 6.4.5 Export test logbook



Fig. 41: Export test logbook

Through the "Export test logbook" mask you can export the data from the SAFELOG device onto a USB stick.

## 6.5 Menu item "Service"



Fig. 42: Menu item "Service"

In this mask you will find the device manufacturer's contact data and the appropriate failure message should system faults arise.

## 6.6 Menu item "Test menu"

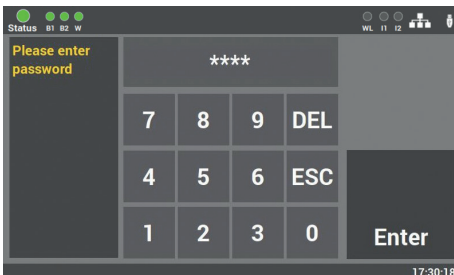

Fig. 43: Password entry at the menu item "Test menu"

Access to the "Test menu" item is password-protected.

You need a separate password for accessing. In the delivery status it is: "1234".

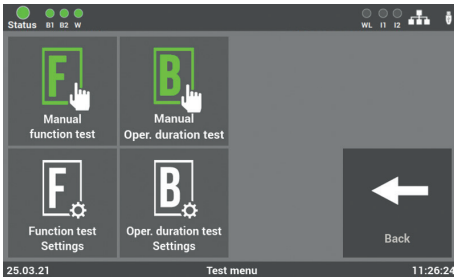

Fig. 44: Menu item "Test menu"

You can manually start the F-test in this mask. Through the "Function test settings" item, you can also configure the settings for the automatic function test.

In the as-delivered state, the "Operating duration test settings" are deactivated and thus not present in the box. See Instruction 6.8.2 to activate the function.

## 6.6.1 Manual function test

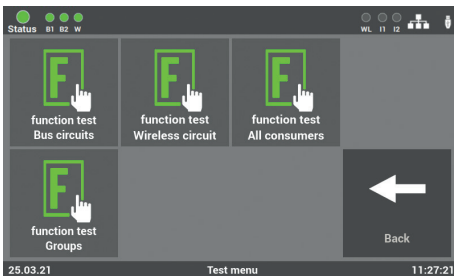

Fig. 45: Mask "Scope of test – Function test"

In this mask you can select whether you want to start the manual function test by selecting the individual bus circuits or the groups.

### 6.6.1.1 Manual function test by bus circuits

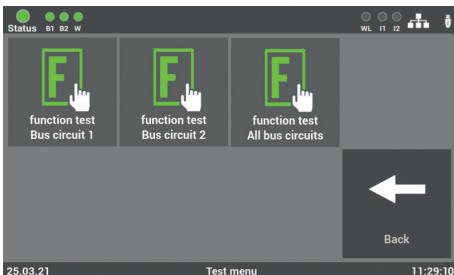

Fig. 46: Mask "Selection of circuits – Function test"

Following selection, a further mask is opened where you can select which bus circuit is to be tested or whether all bus circuits are to be tested.

### 6.6.1.2 Function test - wireless circuit

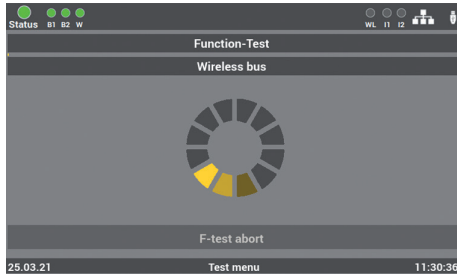

Fig. 47: Mask "Consumers wireless – Function test"

In this mask you can start a function test on the consumers in the wireless circuit.

### 6.6.1.3 Function test of all consumers

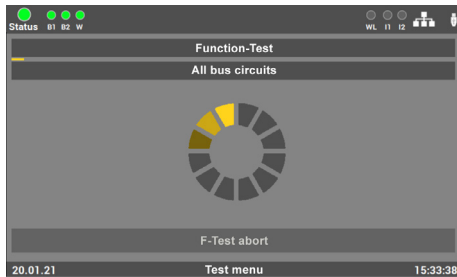

Fig. 48: Mask "All consumers – Function test"

In this mask you can start a function test of all the consumers connected to the system.

### 6.6.1.4 Manual function test by groups

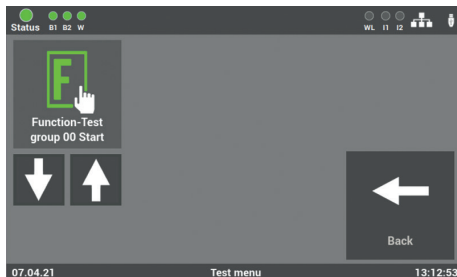

Fig. 49: Mask "Selection of groups – Function test"

In this mask you can start a function test by selecting the group.

The groups of the individual consumers can be assigned by way of the "Settings" menu under the "Consumer data" item.

## 6.6.2 Manual operating duration test

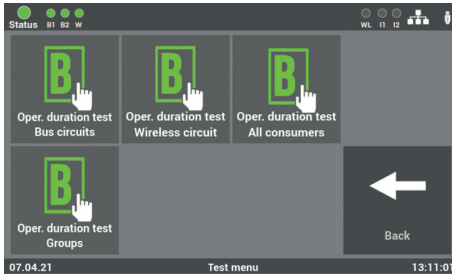

Fig. 50: Mask "Scope of test operating duration test"

In this mask you can select whether you want to start the manual operating duration test by selecting the individual bus circuits or the groups.

### 6.6.2.1 Manual oper. duration test by bus circuits

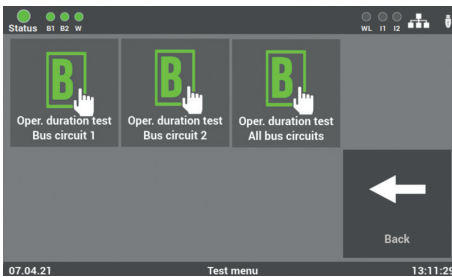

Fig. 51: Mask "Selection of circuits Operating duration test"

Following selection, a further mask is opened where you select which circuit is to be tested or whether all bus circuits are to be tested.

### 6.6.2.2 Operating duration test Wireless circuit

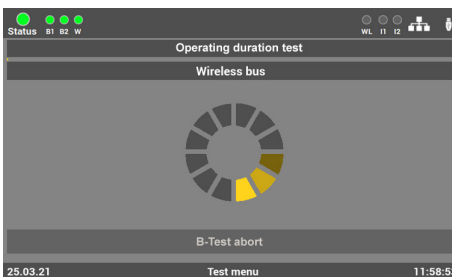

Fig. 52: Mask "Operating duration test Wireless"

This window opens on selecting the "Wireless circuit" operating duration test. Please wait until the consumer search is fully concluded.

### 6.6.2.3 Operating duration test - All consumers

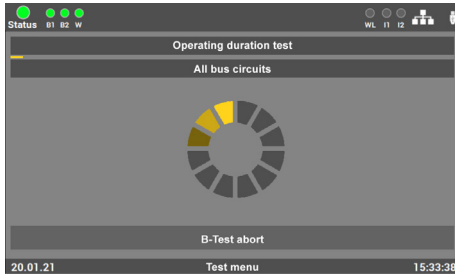

Fig. 53: Mask "Operating duration test – Consumers"

The "Operating duration test All bus circuits" can be carried out when the system is used as a hybrid system or when consumers are connected in the bus and wireless circuit.

### 6.6.2.4 Manual operating duration test by groups

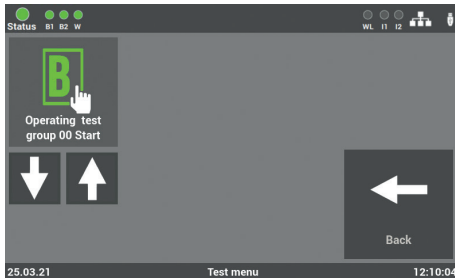

Fig. 54: Mask "Group selection Operating duration test group"

In this mask you can start an operating duration test by selecting the group.

The consumers must be assigned to groups beforehand in the "Settings" menu under the "Consumer data" item.

## 6.6.3 Function test settings

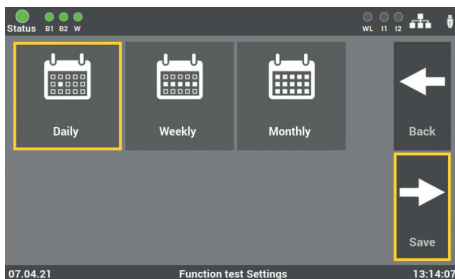

Fig. 55: First mask "Automatic function test"

The function test can be set to reflect the requirement and local circumstances. Firstly select the interval required (daily, weekly or monthly) and confirm with "Save". The "Back" key returns you to the selection menu for the tests.

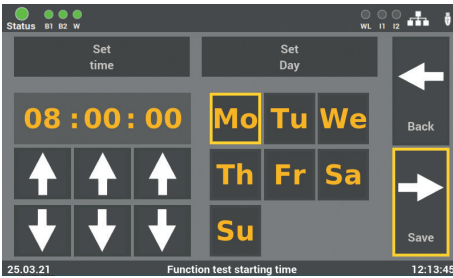

Fig. 56: Second mask  
"Automatic function test"

The time and date for the function test is set in the second mask. It is recommended planning the test in the non-operating periods. The "Save" key concludes the process. The "Back" key gets you to the previous view (without saving).

## 6.6.4 Settings - operating duration test

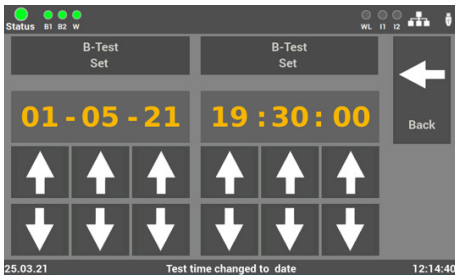

Fig. 57: "Settings - operating duration test"

You can set date and time for the operating duration test given certain requirements.

## 6.7 Menu item "Settings"

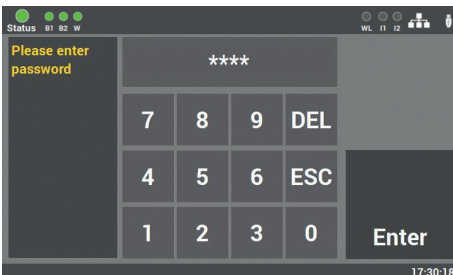

Fig. 58: Password entry at menu item "Settings"

Access to the "Settings" menu item is password-protected.

You need a separate password for access-ing. In the delivery status it is: **"1234"**.



Fig. 59: Menu item "Settings"

This mask has a number of options for programming the connected consumers and the SAFELOG device.

## 6.7.1 Bus circuits

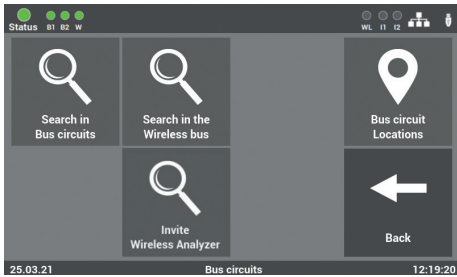

Fig. 60: Mask "Bus circuits"

The functions affecting the individual bus circuits are selected under "Bus circuits".

The following functions can be selected:

- Search in Bus circuits
- Search in the wireless bus
- INVITE

### 6.7.1.1 Finding in bus circuits

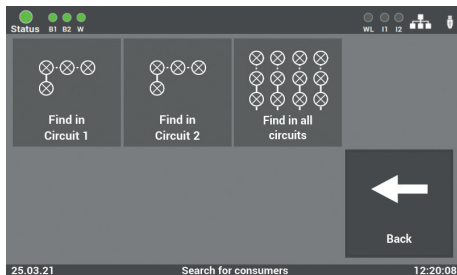

Fig. 61: Mask "Finding consumers"

Finding all connected consumers in the individual circuits or in all of them.

### 6.7.1.2 Search in the wireless bus

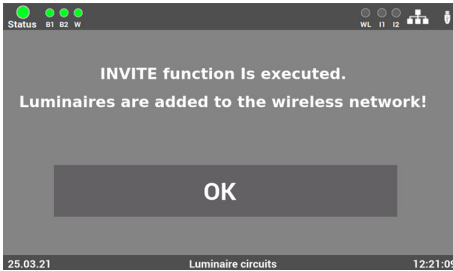

Fig. 62: Mask "Finding in the wireless bus"

The INVITE function is used to find all active consumers in the wireless bus and add them to the wireless network. The scan must be confirmed with "OK".

**This can take a few minutes and cannot be interrupted.**

### 6.7.1.3 Bus circuit locations

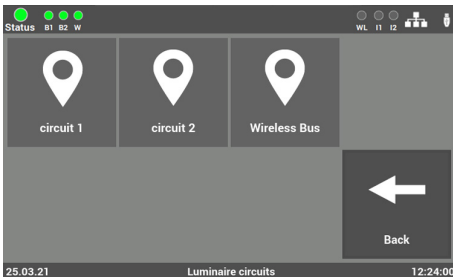

Fig. 63: Mask "Circuit locations"

The bus circuit names can be entered in this "Settings" menu item. These names then appear wherever the circuit designations had previously been.

The entry is limited to 12 characters.

**Avoid any double names! You make it to subsequently find the individual circuits or consumers. Select the circuit that you want to name in this mask.**

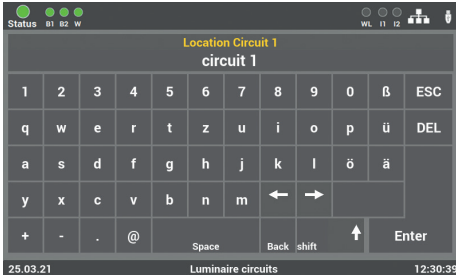

Fig. 64: Enter bus circuit name

In the following mask you can directly enter the names by way of the indicated keyboard. This is accepted from confirmation of the enter key.

## 6.7.2 Consumer data

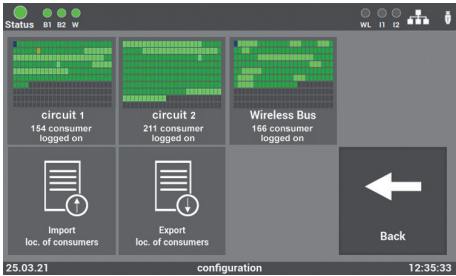

Fig. 65: "Selection Bus circuits"

To select the individual consumers, select the bus circuit in question from the selection menu.

### 6.7.2.1 Consumers in the bus circuit

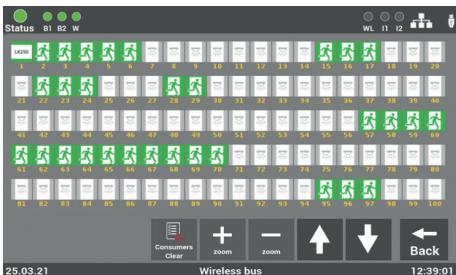

Fig. 66: "Overview of all consumers"

An overview is opened in which all consumers of the selected bus circuit are shown. In the first view, all the connected consumers can always be seen.

The colour of the icons in the illustration indicates the state of the consumers.

Consumers	On	Off	In the battery operation	In the case of a fault
Exit sign luminaire				
Escape route luminaire				
NVG				
Repeater				
line coupler				

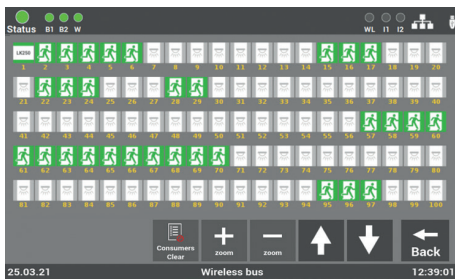

Fig. 67: "Overview Bus circuit - centre view"

Press the "+/-" zoom keys to enlarge the view or reduced it in size. Moreover, the view can be adjusted by selecting the required consumer. Scrolling through the view can be done with the arrow keys.



Fig. 68: "Overview Selection of consumers"

In this view, the required consumer can be opened from the direct selection and the other functions of the consumer selected.

**Two overriding functions which are still in the bus circuit can be selected:**

- Clear all consumers in the circuit
- Change position of the consumers in the circuit

**6.7.2.1.1 Clearing all consumers in the bus circuit**

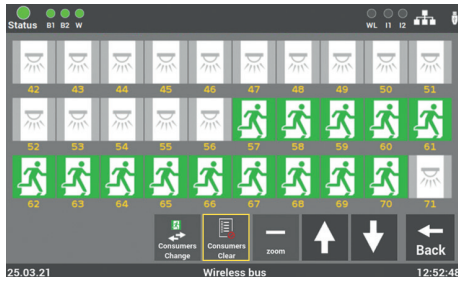

Fig. 69: Clear consumers

The "Clearing consumers" function in this view allows "all" consumers in the selected bus circuit to be cleared.

**6.7.2.1.2 Change consumers in the bus circuit**

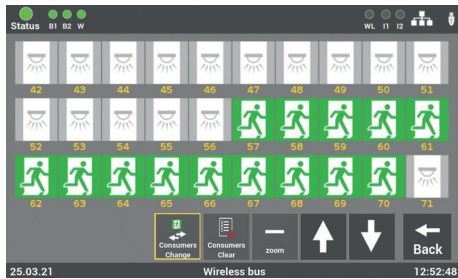

Fig. 70: "Overview of all consumers"

By using the "Change consumers" function, the order of the consumers in the circuit can be adjusted.

Only the consumers one to another can be changed. Changing to an empty position in the circuit is not possible.



Fig. 71: Change consumers

After activating the function, select the first consumer for changing. The second consumer is then selected. Scrolling through the view can be done with the arrow keys.



Fig. 72: Position indication of the changed consumers

The message signals the fact that the positions of the selected consumers have been changed.

### 6.7.2.1.3 Selection of the function

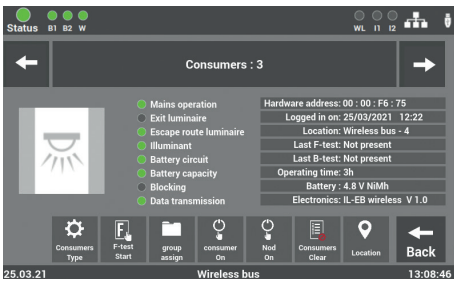

Fig. 73: Mask "Function selection"

To continue with consumer programming, you need to select the function wanted for the programming after selecting the circuits.

The arrows "←/→" allow you to scroll through the consumers.

### The following functions can be selected:

- Location
- Clearing consumers
- Finding consumers → Nod on
- Maintained mode MM on/off (of the consumers in the circuit)
- Group housing
- Start function test
- Consumer type

### 6.7.2.1.4 Entry of consumer locations

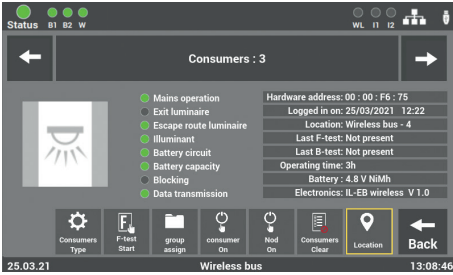

Fig. 74: Mask "Mounting location"

Preselect the individual consumers to change their mounting locations. Following commissioning the consumers are named according to the position in the electrical circuit. Select the corresponding consumer to change its mounting location.

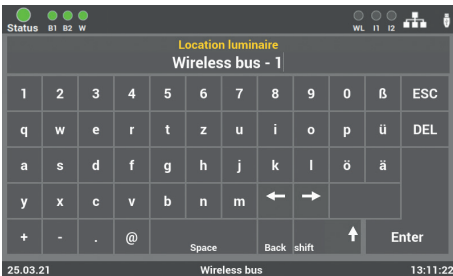

Fig. 75: Mask "Mounting location" – Keyboard

The mounting location is entered in this mask. Confirmation with the Enter key accepts your entry.

The entry is limited to 30 characters.

### 6.7.2.1.5 Clearing consumers

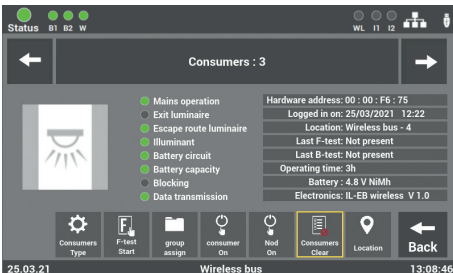

Fig. 76: "Clearing consumers"- individually

The consumer affected is firstly disassembled in the bus circuit before being removed from it with the "Clearing consumers" key.

Any accidentally cleared consumers can be re-inserted in the bus circuit search.

### 6.7.2.1.6 Finding consumers (nod)

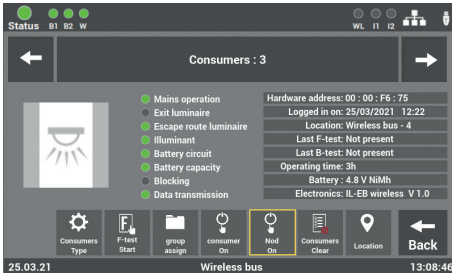

Fig. 77: Mask "Nod"

The function is for searching and finding individual consumers.

To activate the function, select the "Nod on" key. Then the yellow SELF-LED starts to flash at the consumer selected.

### 6.7.2.1.7 Actuate consumers

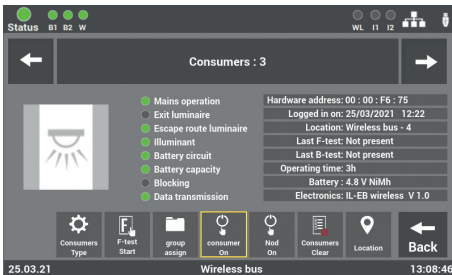

Fig. 78: Mask "MM on/off"

Programming the switch function Non-maintained mode (NMM) / Main-tained mode (MM) of the consumers. You can change the operation mode of the consumers without having to change the wiring at the consumer.

### 6.7.2.1.8 Assign groups

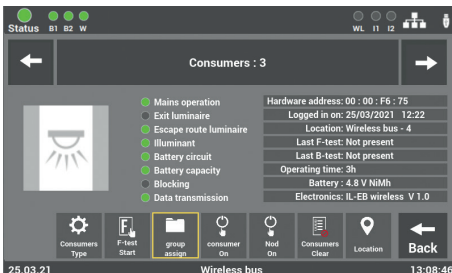

Fig. 79: Mask "Groups"

Following commissioning, all consumers are assigned to the "0" group. This mask allows you to change or re-set group housing.

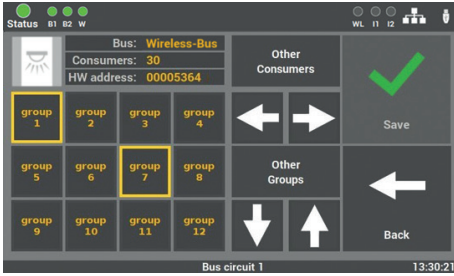

Fig. 80: Mask "Assigning – Groups"

To edit, select the consumer wanted and assign it through selection to the group or groups. Press the arrows "▼/▲" to select other groups.

Confirmation is with the "Save" key. The group must be separately saved for each luminaire before you scroll through the consumers with the arrows "←/→".

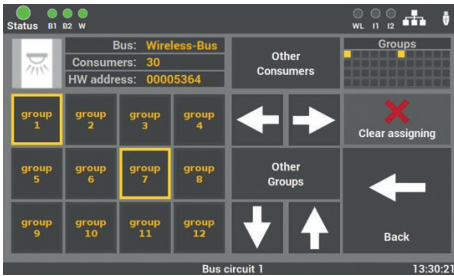

Fig. 81: Mask "Clear groups"

For group assigning purposes, you can individually de-select the groups or remove all of them with the "Clear assign" function. Always confirm your changes with the "Save" key.

The recommendation is to assign only one group to each of the consumers. However on a theoretical basis, up to 48 groups could be assigned to each consumer.

### 6.7.2.1.9 Starting function test of individual consumers

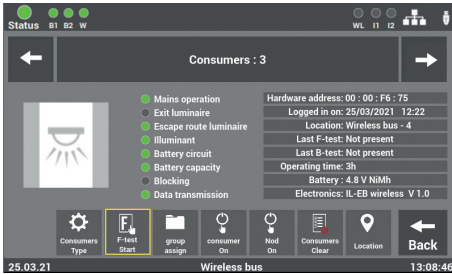

Fig. 82: Mask "F-Test start"

The F-test of every single consumer can be started in the mask.

The F-test at the consumer is set to 5 min.

### 6.7.2.1.10 Change consumer type (Safety / exit luminaires)

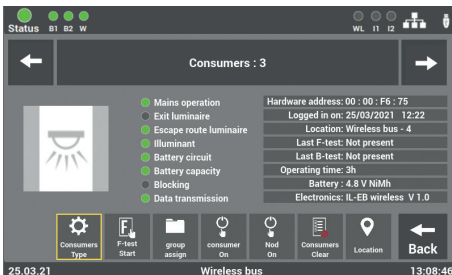

Fig. 83: Mask "Change consumer type"

The "User type" function allows the consumers to be changed between exit sign and escape route luminaires. This function is only possible with luminaires.

### 6.7.2.2 Import and export of consumer location

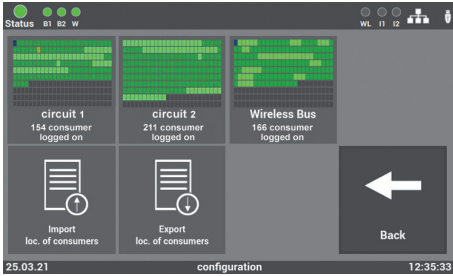

Fig. 84: Import/Export Consumer location

SAFELOG can read in the locations as a file and/or back up the configured locations through the export function. The USB interface at the device interchanges the data.

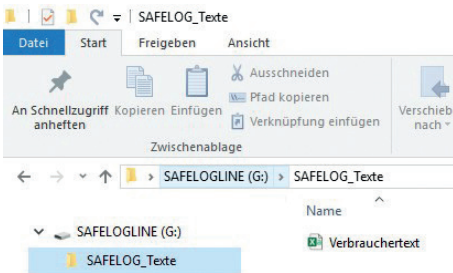

Fig. 85: Folder structure

To read in the data, it must be in the CSV format and the following folder structure must be on the USB stick.

**USB\_Laufwerk\SAFELOG\_Texte\Verbrauchertexte.csv**

**The recommendation after reading out the data onto the USB stick is to back it up on a PC / laptop.**

To facilitate entering the locations, you can read out the data from the device and then edit the location of the consumers on the PC / laptop. In so doing, the corresponding directory is automatically created on the USB stick. To activate the function, press the "Export consumer locations" key.

After data editing, the data is then imported into the device via the "Import consumer locations" key.

### 6.7.3 Devices location of SAFELOG



Fig. 86: Mask "Devices location"- keyboard

Only "SAFELOG" as the default value stands here as the location. By selecting this menu item you adjust the devices location. Entry is via the keyboard and confirmed with the Enter key.

The entry is limited to 12 characters.

### 6.7.4 Timers

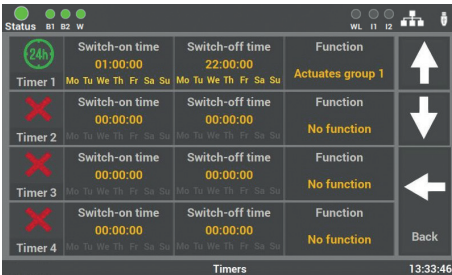

Fig. 87: Mask "Timers"

In the "Timers", menu item you can programme various time functions for the system. 24 timers for this programming are available.

#### 6.7.4.1 Programming sequence

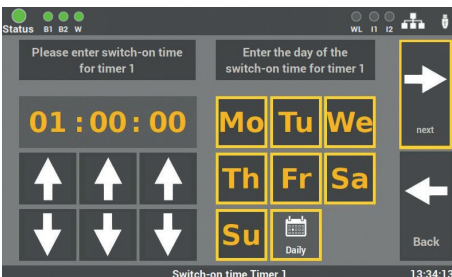

Fig. 88: Mask "Timers – Switch-on time"

**Step 1:** With this mask the time and day is firstly set on which the step established in Step 3 is to begin.

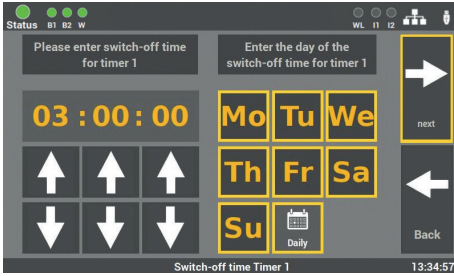

Fig. 89: Mask "Timers – Switch-off time"

**Step 2:** This can be followed up by establishing the time and day on which the step is to be terminated.

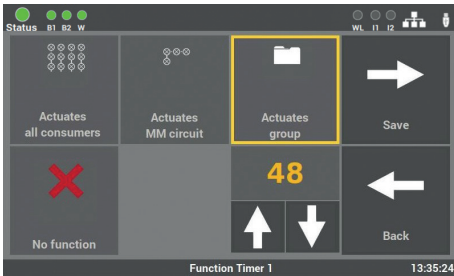

Fig. 90: Mask "Timers – Step selection"

**Step 3:** Finally that step to be carried out is selected:

- Actuates all consumers (MM on / NMM off)
- Switches on MM circuit
- Actuates group
- No function (switch off function)

The group or the bus circuit to be actuated can be selected with the arrow keys. Only one function can be selected for each timer.

### 6.7.5 Inputs/outputs

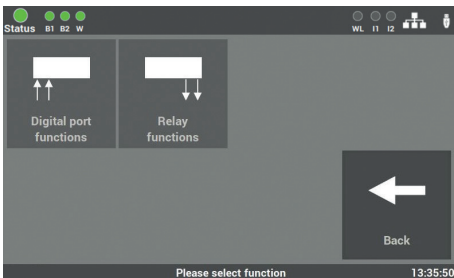

Fig. 91: "Inputs/outputs"

The SAFELOG device has the following inputs and outputs.

## They are:

- 2 control inputs (24V-230V, AC / DC readily programmable)
- 3 relay outputs for messages (readily programmable)

### 6.7.5.1 Control inputs – Selection

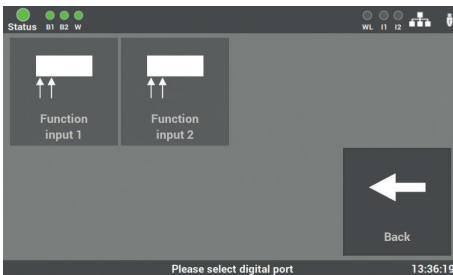

Fig. 92: Mask "Control inputs"

You have two inputs available for selection which you can readily programme. They involve non-floating inputs (24V to 230V AC/DC).

As soon as a signal is on hand at the input, the I1 / I2 display lights up "Green".

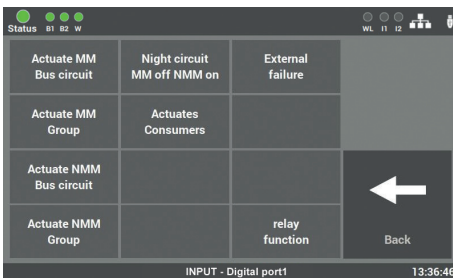

Fig. 93: "Control inputs - functions"

The function is selected in this mask after selecting the input.

## The following functions can be selected:

- Actuate MM bus circuit
- Actuate MM group– the consumers must be assigned to the corresponding group
- Actuate NMM bus circuit
- Actuate NMM group– the consumers must be assigned to the corresponding group

- Night circuit– all MM consumers are switched off and all NMM consumers are switched on
- Actuates consumers – all MM consumers are switched on
- External failure – failures of external devices can be shown
- Inverting function – reversing function, makes possible actuation when no signal at the entry is on hand

### 6.7.5.2 Relay outputs – Selection

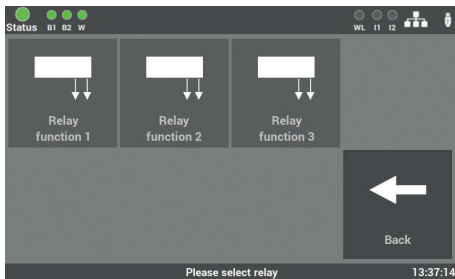

Fig. 94: Mask "Relay outputs"

There are three relay outputs at the SAFELOG device for various messages which can be readily programmed.

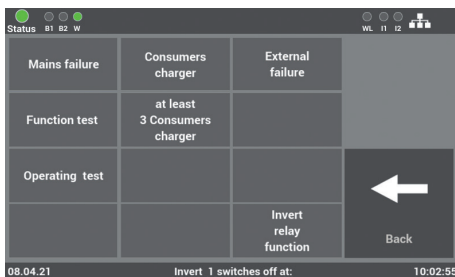

Fig. 95: "Relay outputs - Function"

The function is selected in this mask after selecting the input.

### The following functions can be selected:

- Mains failure
- Function test
- Operating test
- A faulty consumer
- At least 3 consumers are faulty
- Relay function inverted
- External failure

The functions can be adjusted with the Selection menu. Several functions on one relay output is possible.

## 6.7.6 Actuating consumes (NMM/MM)

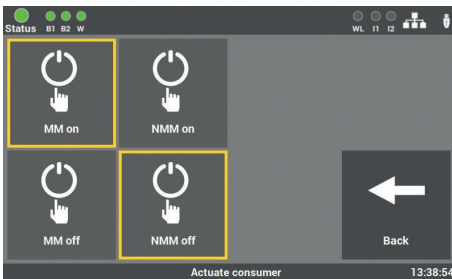

Fig. 96: Actuate consumers

There are a number of possibilities at the SAFELOG device of actuating consumers via the main control unit. The following actuating commands can be carried out:

- MM on / off
- NMM on / off

### 6.7.6.1 Maintained mode – Actuate MM

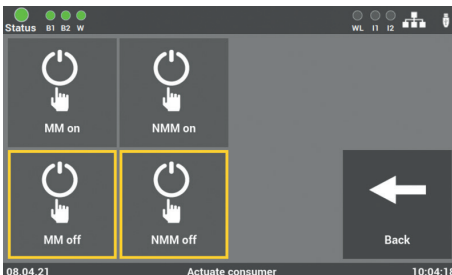

Fig. 97: Mask "Maintained mode off"

In the delivery status the function is activated such that all consumers are in "MM on".

Pressing the "MM off" key switches off these consumers.

### 6.7.6.2 Non-maintained mode - Actuate NMM

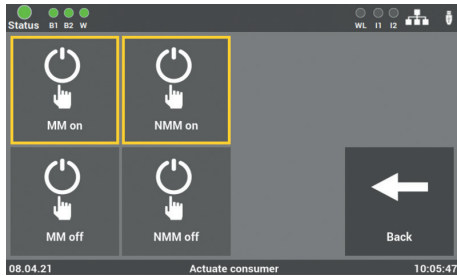

Fig. 98: Mask "Non-maintained mode on"

In the delivery status the function is activated such that all consumers in the non-maintained mode are in "NMM off".

Pressing the "NMM on" function switches on all the consumers.

## 6.8 Menu item "System"

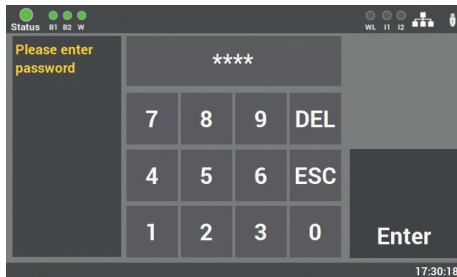

Fig. 99: Password entry under menu item "System"

Access to the "System" menu item is password-protected.

You need a separate password for access. In the delivery status it is: "**1234**".

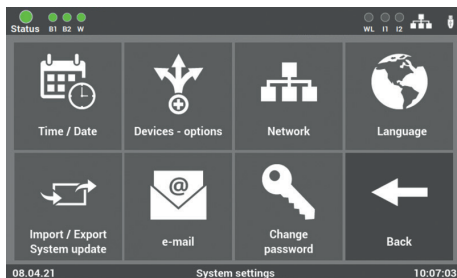

Fig. 100: Menu item "System"

You can undertake settings affecting the SAFELOG device in the mask of menu item "System".

They are the following settings:

- Date / time
- Devices - options
- Network
- Language
- Import/Export
- System update
- E-mail
- Change passwords

### 6.8.1 Changing date and time

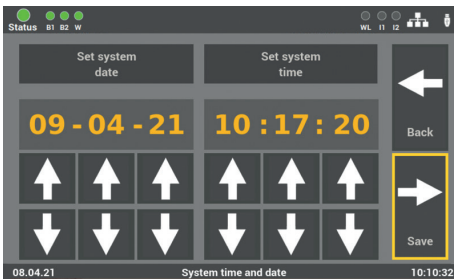

Fig. 101: Mask "Date/Time"

You can set the date and time with the arrow keys in this mask.

### 6.8.2 Devices – Options

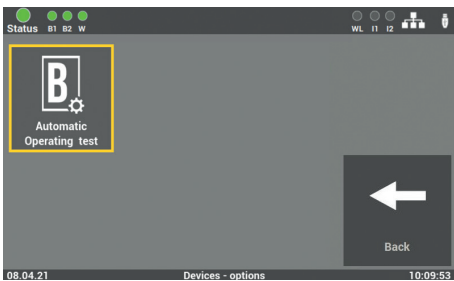

Fig. 102: Mask "Devices options"

You can activate or deactivate the "Automatic continuous operating test" on this level.

## 6.8.3 Network settings

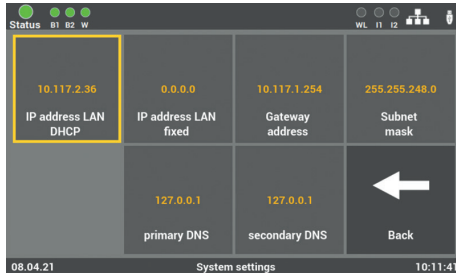

Fig. 103: Menu item "Network"

With this mask you can view settings at the network and also change them, if needed.

### The following settings can be selected:

IP address DHCP	(see Chapter 6.8.3.1)
IP address LAN fixed	(see Chapter 6.8.3.2)
Gateway address	(see Chapter 6.8.3.3)
Subnet	(see Chapter 6.8.3.4)
Primary DNS	(see Chapter 6.8.3.5)
Secondary DNS	(see Chapter 6.8.3.6)

### 6.8.3.1 DHCP address

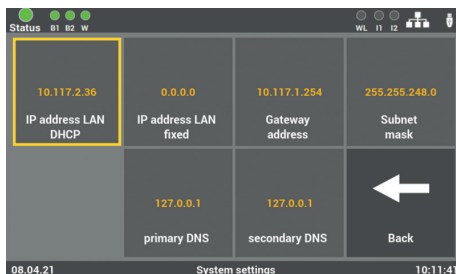

Fig. 104: DHCP address

All SAFELOG devices are delivered as standard with the DHCP setting. The software automatically obtains an IP address from the DHCP server. There is no need for an address to be issued by the network administrator for integration into the network on hand.

### 6.8.3.2 Change static IP address

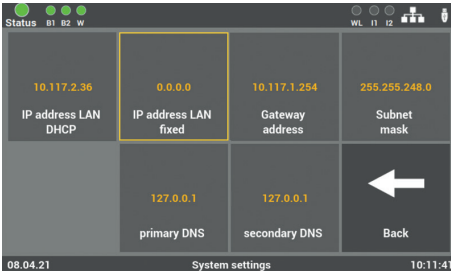

Fig. 105: IP address

You can manually allocate an IP address under this menu item if you want to assign a certain address to the SAFELOG device. The specifications for this are obtainable from the operator / network administrator.

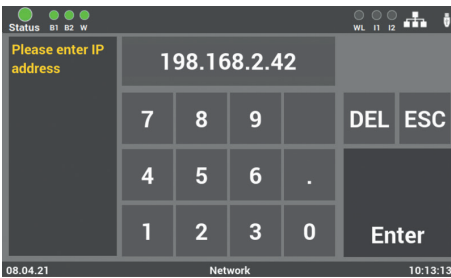

Fig. 106: Mask "Change IP address"

You can directly enter the required IP address in the SAFELOG device via the keyboard of this mask and save it using the "Enter" key.

### 6.8.3.3 Change gateway address

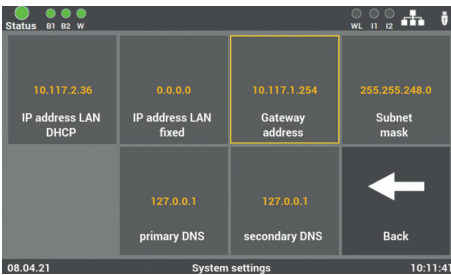

Fig. 107: Gateway address

The input is only needed if you use the static IP address option. The gateway establishes the Internet connection. The specifications for this are obtainable from the operator / network administrator.

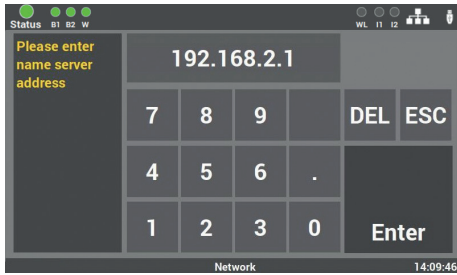

Fig. 108: Mask "Change gateway address"

You can directly enter the address in the SAFELOG device via the keyboard of this mask and save it using the "Enter" key.

### 6.8.3.4 Subnet

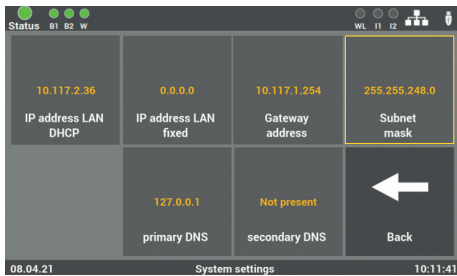

Fig. 109: Mask "Subnetwork address"

On changing the static IP address, the physical ( Subnetwork mask) address of the network must be edited.

### 6.8.3.5 Primary DNS

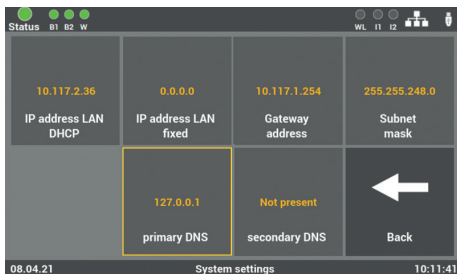

Fig. 110: Mask "Address primary DNS"

The input is only needed if you use the static IP address option. Otherwise the DNS server address is received from the DHCP server. Standard setting in the boxes is: primary DNS 192.168.2.255

Only carry out the changes in consultation with the network administrator.

### 6.8.3.6 Secondary DNS

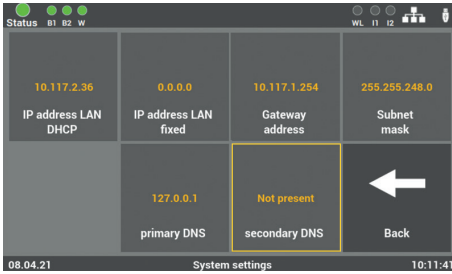

Fig. 111: Mask "Address secondary DNS"

The secondary server is used if the Primary DNS sever is inaccessible. The input is only needed if you use the static IP address option. Otherwise the DNS server address is received from the DHCP server. Standard setting in the boxes is: secondary DNS 192.168.2.254.

Only carry out the changes in consultation with the network administrator.

### 6.8.4 Changing the language

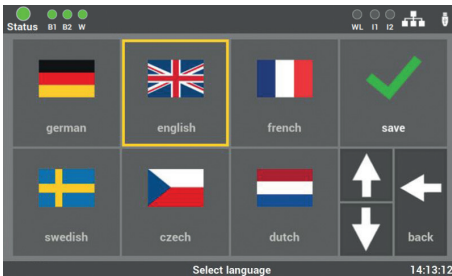

Fig. 112: Mask "Language"

You can make a choice between the various languages in this mask. After the language change, the SAFELOG device switches. The texts entered for the locations etc. remain in place. If necessary, manually change the texts.

### 6.8.5 Changing system data ("Import/Export")

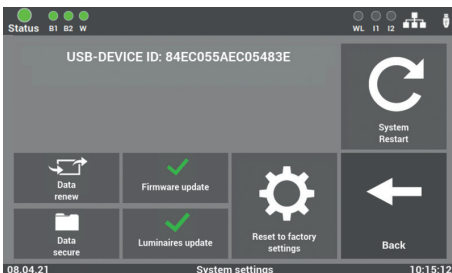

Fig. 113: Mask "Change system data"

An Update routine with various options to select is opened here.

**The re-start is necessary  
for all changes to be  
accepted.**

### 6.8.5.1 Reset to factory settings

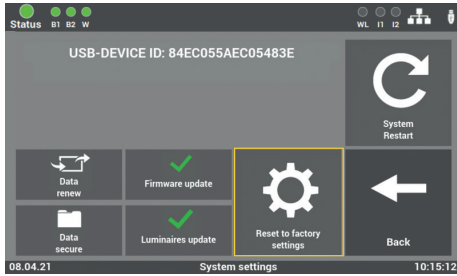

Fig. 114: Mask "Reset to factory settings"

All programmed values and data are cleared and the delivery status default values entered. After activating the key, the system must be placed back into operation.

### 6.8.5.2 Data secure

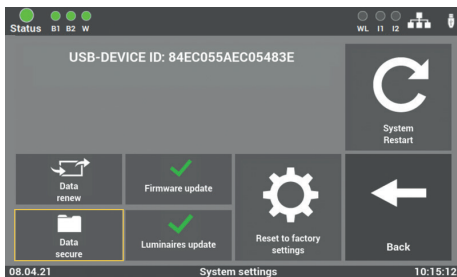

Fig. 115: Mask "Secure data"

All changed values, data and programmes are saved on the USB stick.

### 6.8.5.3 Renew data

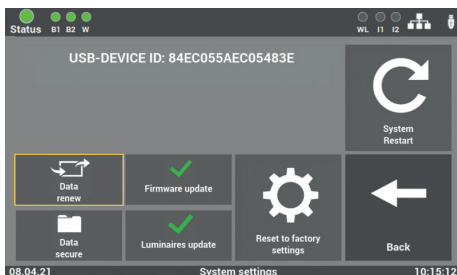

Fig. 116: Mask "Data renew"

In this menu item you can reset the previously saved data (key "Software secure").

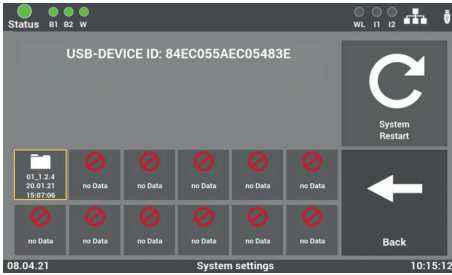

Fig. 117: Mask "Securing selection"

If you have saved the software several times over, then select the corresponding securing from the USB stick.

#### 6.8.5.4 Update activate

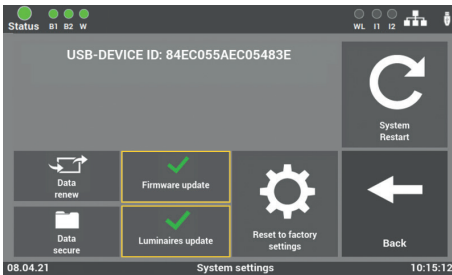

Fig. 118: Mask "Update activate"

Activate the update after renewing the corresponding data in the SAFELOG device. The function activates the last installed update on the SAFELOG device. Not activating the function results in non-acceptance of the replaced data.

#### 6.8.5.5 System start

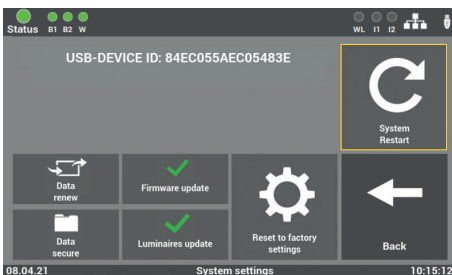

Fig. 119: Mask "System start"

You can restart the system with the function. The restart ends the update routine and you get back to the main menu.

Only use the software made available to you by the Service of the manufacturer/supplier. Any other software is not authorized and its use could place the system out of operation.

If you have received an update for the device software from the manufacturer/supplier of the system, then import the software into the SAFELOG device via this programme item. Apply the following key sequence after reading in and activating the changes in order to transcribe the new values into the SAFELOG device:

**„Carry out firmware update“ → „System restart“**

## 6.8.6 Configuration of e-mail settings

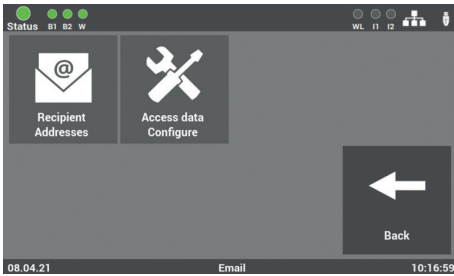

Fig. 120: "Change password"

Here you enter the data for sending e-mails. You can create up to 12 recipients in the main control unit. In addition, you can save various configurations for every recipient.

### 6.8.6.1 Configure recipient address

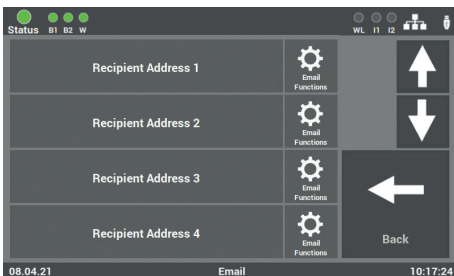

Fig. 121: "Configure recipient"

Select the recipient of the message in this mask and determine the message through which the recipient is to be informed.

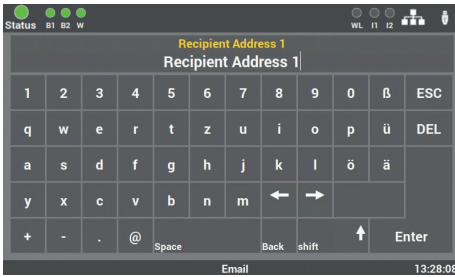

Fig. 122: Mask "Enter recipient address"

Enter the name of the recipient of the mail here. Simply remove the e-mail address in this box to clear the recipient.

The entry is limited to 40 characters.

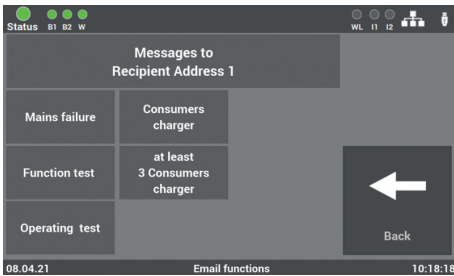

Fig. 123: Mask "Select recipient messages"

Select the messages in this mask which the recipient is to receive.

### 6.8.6.2 Settings for e-mail dispatching

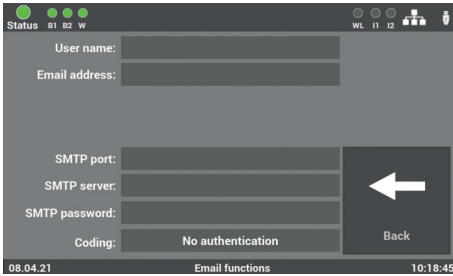

Fig. 124: Mask "E-mail dispatching"

Enter the data required for configuring the access in this mask.

The data is obtained from your Internet provider or your IT Dept.

### 6.8.7 Change password

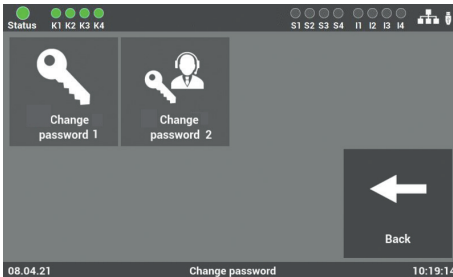

Fig. 125: Mask "Change password"

Any password on hand can be changed in this mask. For this, only preselect the password required and enter the new password.

**Password 1 = Accessing the main menu (Level 1 factory settings: "0000")**

**Password 2 = Accessing the extended settings: Test menu and system settings (Level 2 factory settings: "1234")**

## 7. Web Visualisation

### Using the WEB browser to enter the address



**Connection example:**  
Direct access via IP address,  
e. g.: 192.168.110.247

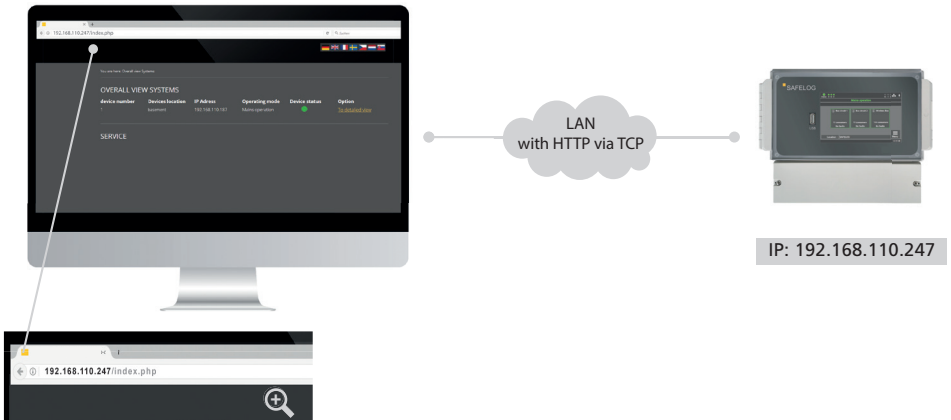

Fig. 126: SAFELOG device and Web visualisation

By way of the web interface of the SAFELOG device, a web browser can be used to depict the status information on the system.

### Connection to the visualisation

Connect the SAFELOG device to a local network. The SAFELOG device is preselected by entering the IP address in the web browser address line. This is found in the SAFELOG device (see Chapter "Network settings"). Access to the SAFELOG device in the network must be administered and set up by an IT department with due responsibility.

## 7.1 Overall view

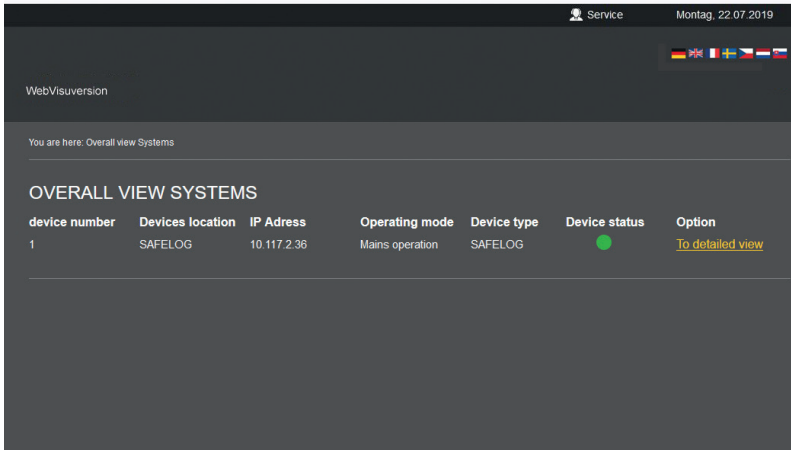

Service Montag, 22.07.2019

WebVisuersion

You are here: Overall view Systems

### OVERALL VIEW SYSTEMS

device number	Devices location	IP Address	Operating mode	Device type	Device status	Option
1	SAFELOG	10.117.2.36	Mains operation	SAFELOG	<span style="color: green;">●</span>	<a href="#">To detailed view</a>

Fig. 127: Overall view

In the overall view mask you can see the state of the SAFELOG system as opened from the web address.

**The overview reveals the following information on the SAFELOG device:**

- **Device number:** Numbering the SAFELOG device is automatically issued by the main control unit
- **Devices location:** You can change the location under the item - "Devices location of the SAFELOG device"
- **IP address**
- **Operating mode:** The operating mode (battery or mains operation) of the SAFELOG device
- **Device type:** The SAFELOG device type
- **Device status:** Status of the SAFELOG device and the connected consumers

## 7.2 Detailed view

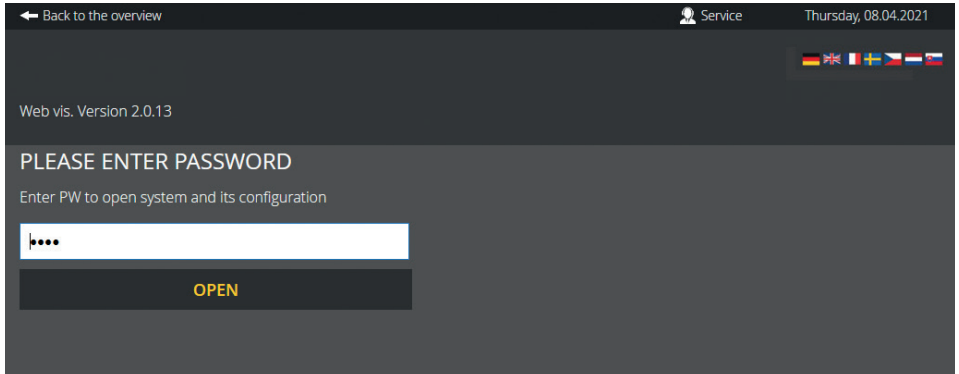

Fig. 128: Password request Detailed view

A password shields the detail view from unauthorised interference. Enter the access code to get to the detailed information of the selected system. In the delivery status it is: "0000".

**The password you are inputting here is the same one that you directly entered at the SAFELOG device on accessing the Test menu, Settings and System (see Chapter "Test menu", "Settings" and "System").**

## 7.2.1 Elements of the detailed view

You get to the detailed view on entering the correct accessing code.

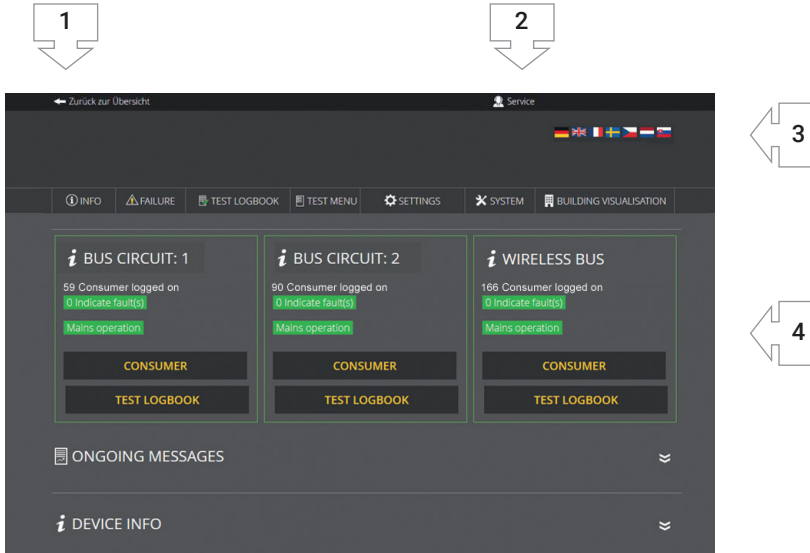

Fig. 129: Main menu - Detailed view

The following elements can be seen throughout in the detailed view and are operable:

1. **Back to the overall view:** This link takes you back to the overall view.
2. **Service link:** Link to the contact data of the after-sales service and to the SAFELOG device overall view.
3. **Language choice:** The language selector allows you to change the web visualisation operating language. Click on the flag to choose between German, English and French as the operating language. Whilst the language in the user interface is changed, no change is made to the data in the SAFELOG device.
4. **Status display:** Explanation in the "Status display" chapter.

## 7.2.2 Status display

Both bus circuits of the SAFELOG device are shown here as well as the logged on consumers. Any failures are also shown in the status display. An overview of all consumers is opened by way of "Display consumers" and for the corresponding bus circuits circuit this is shown via the "Test logbook"

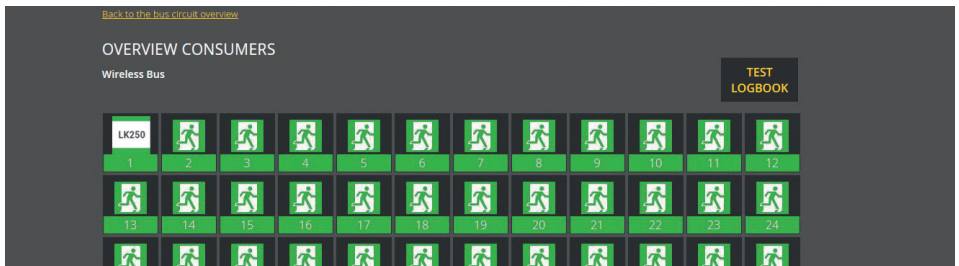

Fig. 130: Overview consumers

The consumer overview shows all consumers with the corresponding icon. The test logbook can also be opened here.

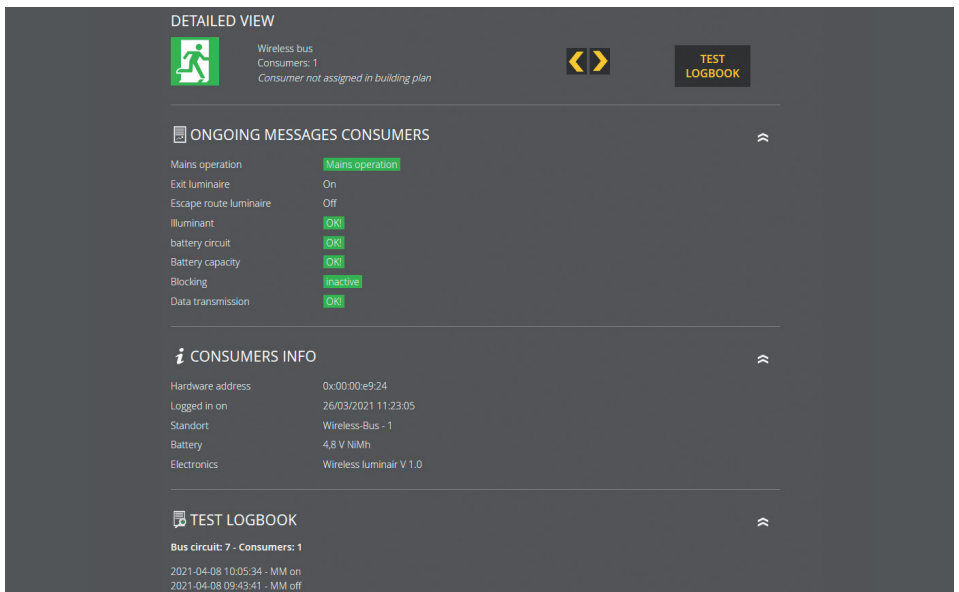

Fig. 131: Detailed view Consumers

A mouse click on a logged on consumer opens a detailed view of the consumer selected. Changing to the next logged on consumers can be done with the arrows. Otherwise, the consumer info is shown on the detailed view as well as the test logbook of this consumer.

### 7.2.3 Main menu

The main menu consists of the following 7 areas:

- Info
- Failure
- Test logbook
- Test menu
- Settings
- System
- Building visualisation

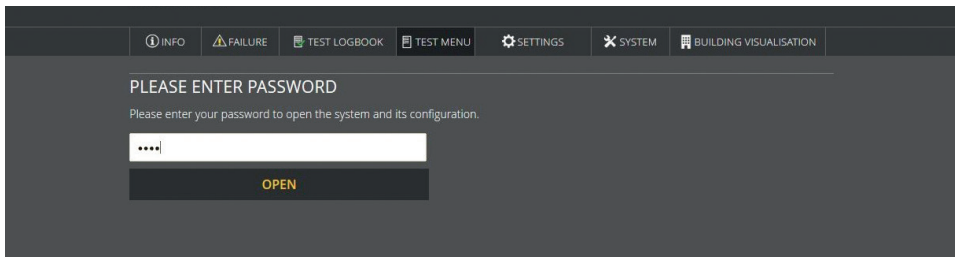

Fig. 132: Expanded areas

A second password protects the menu items of Test menu, Settings, System and Building visualisation. In the delivery status it is: "1234".

**The password you are inputting here is the same one that you directly entered at the SAFELOG device on accessing the Test menu, Settings and System (see Chapter "Test menu", "Settings" and "System").**

## 7.2.4 Submenu

Each of the main menu items of Info, Test logbook, Test menu, Settings and System have subordinate areas. You can open them by running the mouse across the menu item in question.

The areas of the menu items are folded in the normal state:

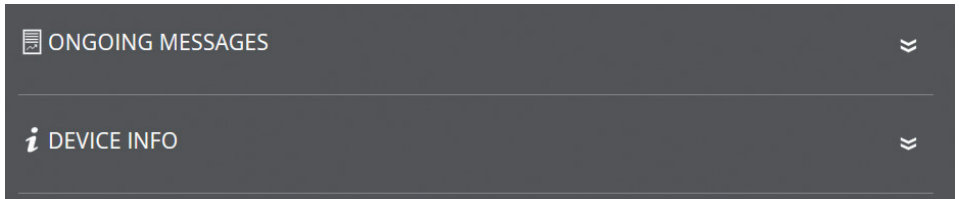

Fig. 133: Retracted areas

The area on being clicked opens and all its contents become visible:

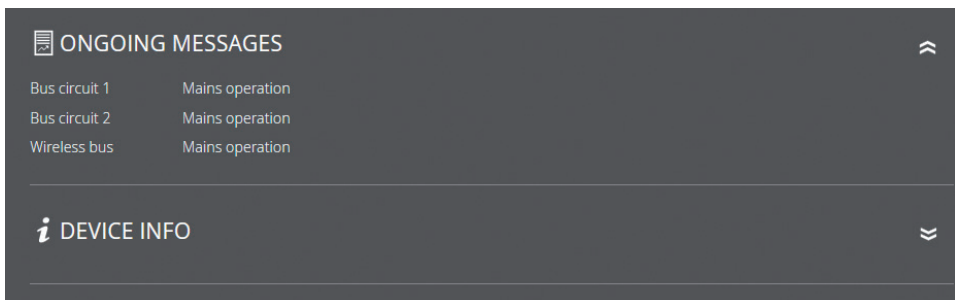

Fig. 134: Expanded areas

The contents are closed by again clicking the area.

## 7.2.5 Info

The Info menu item is the automatic home page of the detailed view. A general overview is provided in this menu item of the SAFELOG device and the connected consumers. Here you can see all the ongoing system messages and an overview of the SAFELOG device status (Device info). The menu item is only for information purposes. No data can be changed here.

### Ongoing message

This where you receive the information on the status of both the bus circuits. Shown is whether they are in the battery operation or in mains operation.

### Device info

All important data and state of the SAFELOG device are listed here.

## 7.2.6 Failure

This menu item gets you to the failure page displaying all the up-coming failure messages and/or faults in plain text.

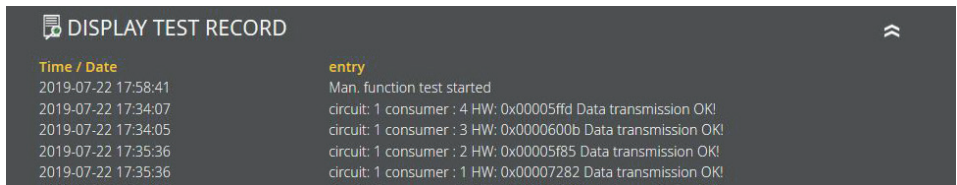

Fig. 135: Failure

## 7.2.7 Test logbook

Through this menu item you obtain an insight into all the logged recordings of the system. Here you can also document work carried out and export all data as a CSV file.

### 7.2.7.1 Display test logbook



Time / Date	entry
2019-07-22 17:58:41	Man. function test started
2019-07-22 17:34:07	circuit: 1 consumer : 4 HW: 0x00005ffd Data transmission OK!
2019-07-22 17:34:05	circuit: 1 consumer : 3 HW: 0x0000600b Data transmission OK!
2019-07-22 17:35:36	circuit: 1 consumer : 2 HW: 0x00005f85 Data transmission OK!
2019-07-22 17:35:36	circuit: 1 consumer : 1 HW: 0x00007282 Data transmission OK!

Fig. 136: Display test logbook

The last 20 entries and messages are documented in this area. The "Test logbook export" menu item allows you to export all the entries and messages into a CSV file.

### 7.2.7.2 Result last function test

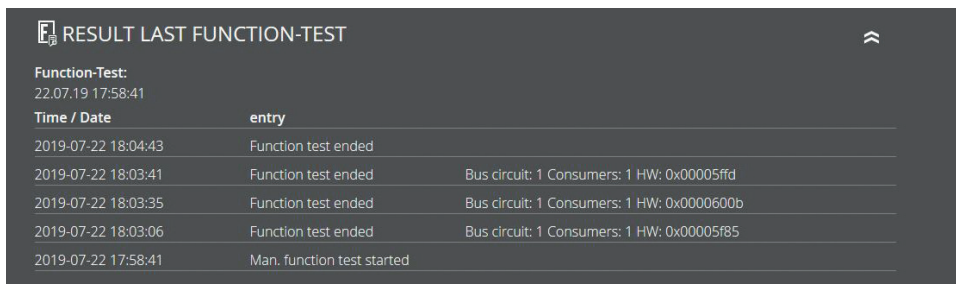

Time / Date	entry
2019-07-22 18:04:43	Function test ended
2019-07-22 18:03:41	Function test ended Bus circuit: 1 Consumers: 1 HW: 0x00005ffd
2019-07-22 18:03:35	Function test ended Bus circuit: 1 Consumers: 1 HW: 0x0000600b
2019-07-22 18:03:06	Function test ended Bus circuit: 1 Consumers: 1 HW: 0x00005f85
2019-07-22 17:58:41	Man. function test started

Fig. 137: Result last function test

This area provides a compact overview of the result of the last function test.

### 7.2.7.3 Result last operating test

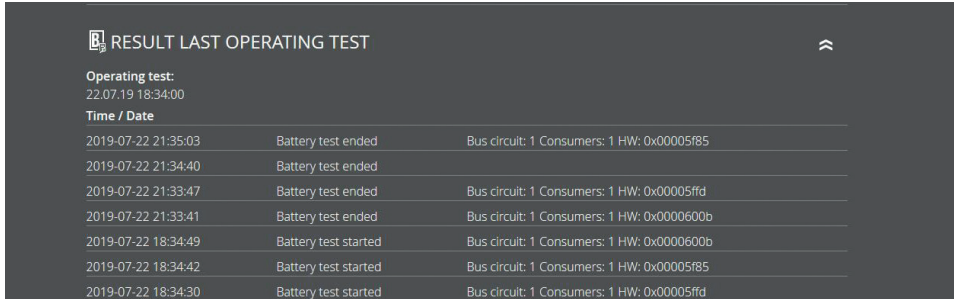

**RESULT LAST OPERATING TEST**

Operating test:  
22.07.19 18:34:00

Time / Date

2019-07-22 21:35:03	Battery test ended	Bus circuit: 1 Consumers: 1 HW: 0x00005f85
2019-07-22 21:34:40	Battery test ended	
2019-07-22 21:33:47	Battery test ended	Bus circuit: 1 Consumers: 1 HW: 0x00005fd
2019-07-22 21:33:41	Battery test ended	Bus circuit: 1 Consumers: 1 HW: 0x0000600b
2019-07-22 18:34:49	Battery test started	Bus circuit: 1 Consumers: 1 HW: 0x0000600b
2019-07-22 18:34:42	Battery test started	Bus circuit: 1 Consumers: 1 HW: 0x00005f85
2019-07-22 18:34:30	Battery test started	Bus circuit: 1 Consumers: 1 HW: 0x00005fd

Fig. 138: Result last operating test

This area provides a compact overview of the result of the last operating test. You can also export and download the results of the last test as a CSV file.

### 7.2.7.4 Manual documentation



**MANUAL DOCUMENTATION**

**Maintenance carried out**  
08.04.2021 13:06:49

**SAVE**

**Consumers serviced**  
08.04.2021 13:06:49

Please choose

Please choose

**SAVE**

Fig. 139: Manual documentation

All the work carried out at the SAFELOG device can be documented here in the test log-book: "**Maintenance carried out**" or "**Consumers serviced**".

The "Consumer serviced" mask allows you to select the corresponding bus circuit and consumer.

### 7.2.7.5 Export test logbook

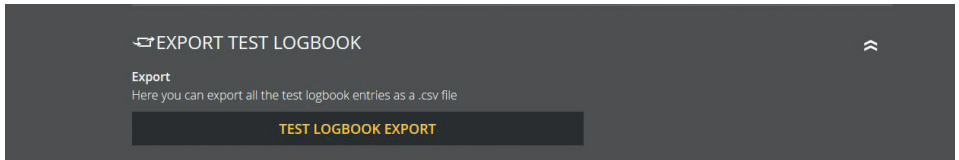

Fig. 140: Export test logbook

The "Test logbook export" area allows you to export and download all the test logbook entries and messages into a CSV file.

## 7.2.8 Test menu

Through the "Test menu" menu item you can manually start the function test and - by means of the "Function test settings" - configure the settings for the automatic function start.

### 7.2.8.1 Manual function test

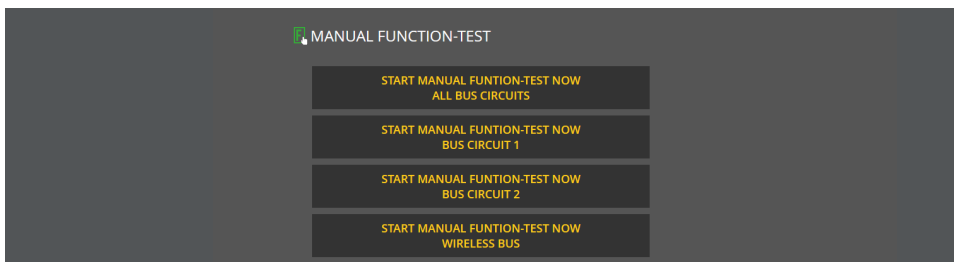

Fig. 141: Manual function test

By pressing a button here you can manually start a function test for both circuits or for one bus circuit. You receive an info if the function test start is successful.

**Please note that the function test takes some time.**

### 7.2.8.2 Manual operating test

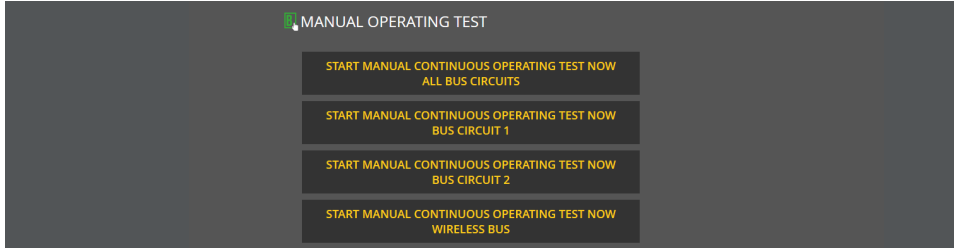

Fig. 142: Manual operating test

By pressing a button here you can manually start a continuous operating test for all circuits or for one bus circuit. You receive an info if the test start is successful.

### 7.2.8.3 Function test settings

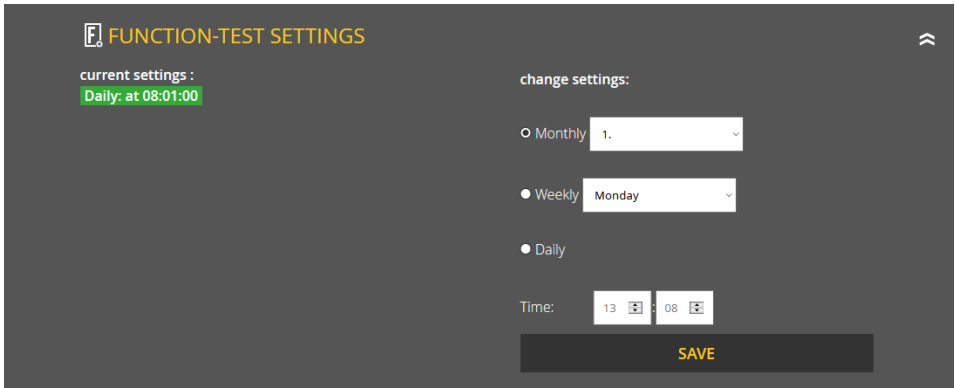

Fig. 143: Function test settings

Under the function test settings, you can view and edit the currently set interval for the automatic function test.

**Please note the time must always be indicated. Under the "monthly" selection as interval, the day in the month is needed and under the "weekly" selection the need is for the day of the week.**

### 7.2.8.4 Operating duration test settings

**B** CONTINUOUS OPERATING TEST SETTINGS

Continuous operating test settings

One-day continuous operating 01.05.2021

Clock time continuous operating 19:30

test:  **SAVE**

Fig. 144: Settings - operating duration test

Under the settings, you can view and edit the currently set time interval for the automatic continuous operating test.

## 7.2.9 Settings

Settings gives you a number of options to programme the connected consumers and the SAFELOG device.

### 7.2.9.1 Bus circuits

**B** BUS CIRCUITS

circuit 1: circuit 2: Wireless bus:

circuit 1 circuit 2 Wireless Bus

**SAVE** **SAVE** **SAVE**

Fig. 145: Bus circuits

You can designate two bus circuits in this area. These names then appear wherever the circuit designations had previously been. The entry is limited to 12 characters.

**Avoid any double names! This makes it difficult to subsequently find the individual circuits or consumers in the load circuit.**

### 7.2.9.2 Consumer data - Bus circuits

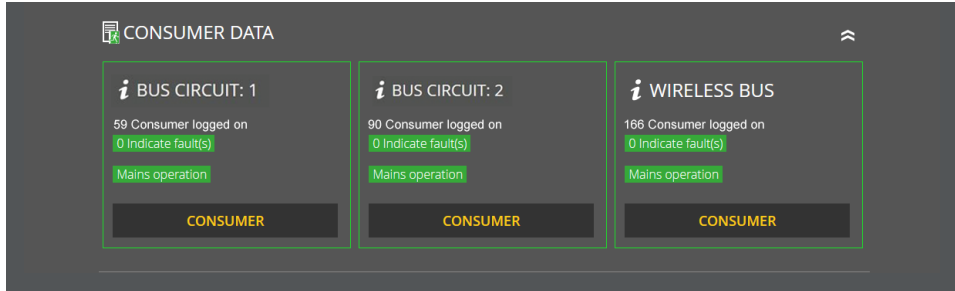

Fig. 146: Consumer data - Bus circuits

Both bus circuits are listed under consumer data as they are with the status menu. The consumer overview is retrievable by the button showing all the bus circuit consumers.

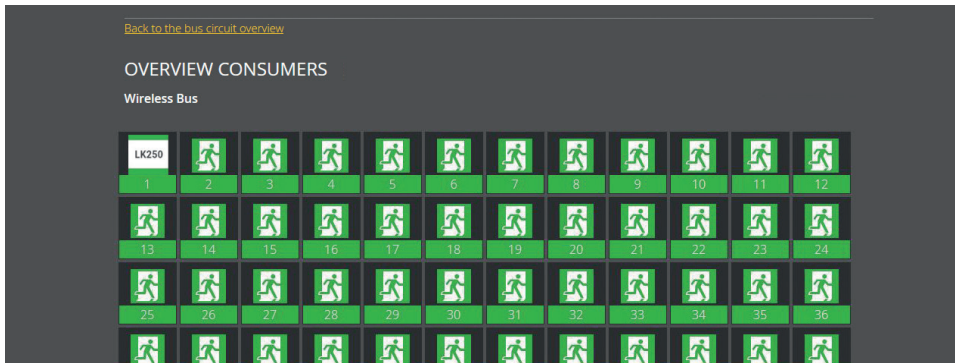

Fig. 147: Overview consumers

A mouse click on a logged on consumer shows the detailed page of the consumer. In addition to the information retrievable under the status menu, you also have here the **following options**:

- Change consumer locations: location of the consumer
- Change consumers
- F-Test consumers
- Consumers - switch on / off
- Consumer MM/NMM type
- Change group assigning

**Consumers Change**  
This consumer (Bus circuit: Wireless bus Position: 1) Change with:  
Consumers 2

SAVE

**F-test Consumers**

F-TEST RESTART

**Consumer ON/OFF**

CONSUMER OFF

**Consumers Type**

CONSUMERS TYPE

**Change group assigning**

Group 1    Group 2    Group 3    Group 4    Group 5    Group 6    Group 7  
 Group 8    Group 9    Group 10    Group 11    Group 12    Group 13    Group 14  
 Group 15    Group 16    Group 17    Group 18    Group 19    Group 20    Group 21  
 Group 22    Group 23    Group 24    Group 25    Group 26    Group 27    Group 28  
 Group 29    Group 30    Group 31    Group 32

SAVE

**ONGOING MESSAGES CONSUMERS**

Mains operation: Mains operation  
 Exit luminaire: On  
 Escape route luminaire: Off  
 Illuminant: OK  
 battery circuit: OK  
 Battery capacity: OK  
 Blocking: inactive  
 Data transmission: OK

**CONSUMERS INFO**

Hardware address: 0x00:00:e9:24  
 Logged in on: 26/03/2021 11:23:05  
 Standort: Wireless-Bus - 1  
 Battery: 4.8 V NiMH

Fig. 148: Overview consumers

**IMPORT / EXPORT CONSUMER LOCATIONS**

**export luminaire data as .csv file**

Click on >Export luminaires data< to download the current data of the luminaires and circuits in the CSV format.

EXPORT LUMINAIRE DATA

**import luminaire data (.csv file)**

Please note that the specified .csv file format must be adhered to. Through the luminaires data export you can download the correct format with the current luminaires data and use as a template.

Browse: No file selected

IMPORT LUMINAIRE DATA

Fig. 149: Import / Export

### 7.2.9.3 Devices location

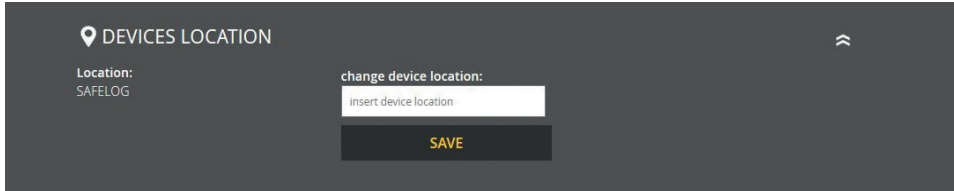

DEVICES LOCATION

Location:  
SAFELOG

change device location:

insert device location

SAVE

Fig. 150: Devices location

You can adjust the devices location in this area. Only "SAFELOG" as the default value stands here as the location.

The entry is limited to 12 characters.

### 7.2.9.4 Timers

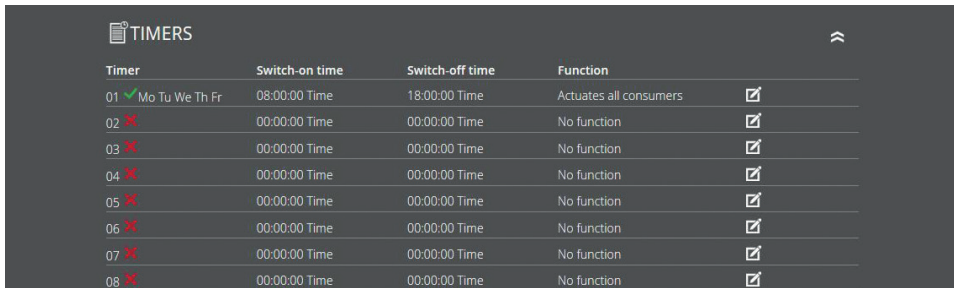

Timer	Switch-on time	Switch-off time	Function	
01 ✓ Mo Tu We Th Fr	08:00:00 Time	18:00:00 Time	Actuates all consumers	✕
02 ✕	00:00:00 Time	00:00:00 Time	No function	✕
03 ✕	00:00:00 Time	00:00:00 Time	No function	✕
04 ✕	00:00:00 Time	00:00:00 Time	No function	✕
05 ✕	00:00:00 Time	00:00:00 Time	No function	✕
06 ✕	00:00:00 Time	00:00:00 Time	No function	✕
07 ✕	00:00:00 Time	00:00:00 Time	No function	✕
08 ✕	00:00:00 Time	00:00:00 Time	No function	✕

Fig. 151: Timers

In this area you can programme various time functions for the system. 24 timers for this programming are available.

All the active timers are marked with the green tick. Additional data on the timer (day of the week, switch-on time, switch-off time, function) can be taken from the corresponding line.

**The red X signifies no function for the timer in question i.e. it is inactive.**

You can edit or activate a timer by clicking the associated button. With the page re-loaded, you are now provided with various setting possibilities for the timer (see 01. in Fig. 149). To deactivate an active timer, click on the button to be edited and select under Function "no function" as the next step.

### 7.2.9.5 Potential-free control inputs (Digital port functions)

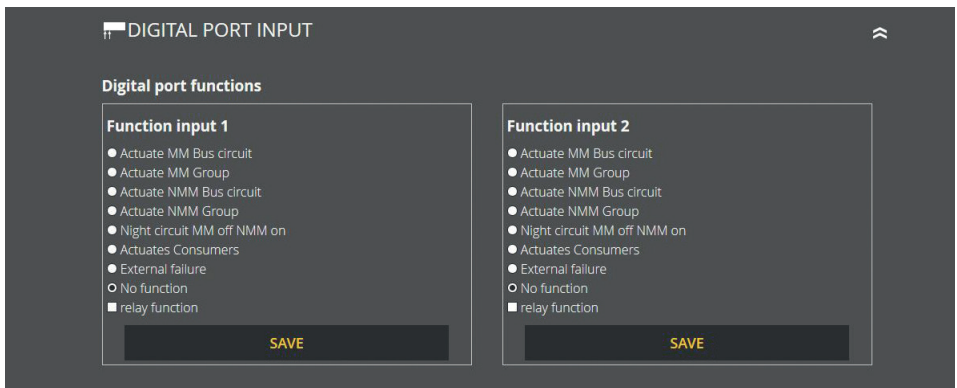

Fig. 152: Digital port inputs

In this area you can readily programme the two digital inputs.

#### The following functions can be selected:

- Actuate MM Bus circuit 1- 2
- Actuate MM Group 1 - 48
- Actuate NMM Bus circuit 1 - 2
- Actuate NMM Group 1 - 48
- Night circuit MM off NMM on
- Actuates consumers
- External failure
- No function
- Inverting functions

### 7.2.9.6 Relay outputs – Selection

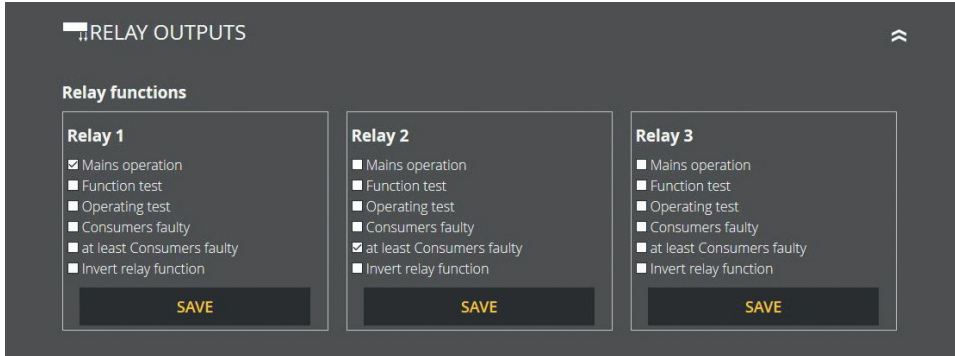

Fig. 153: Relay outputs

There are three relay outputs at the SAFELOG device for various messages which can be readily programmed in this area.

#### The following functions can be selected:

- Mains failure
- Function test
- Operating test
- Faulty consumer
- At least 3 consumers are faulty
- Invert relay function

The functions can be correspondingly adjusted with the Selection menu. Several functions can also be applied to one relay output.

### 7.2.9.7 Actuate consumers

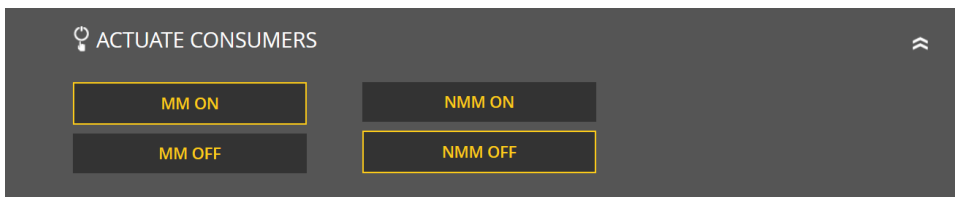

Fig. 154: Actuate consumers

There are a number of possibilities at the Web visualisation of actuating luminaires via the main control unit. The following actuating commands can be carried out:

- MM on / off
- NMM off / on

## 7.2.10 System

You can undertake settings affecting the SAFELOG device in the "System" menu.

### 7.2.10.1 Network settings

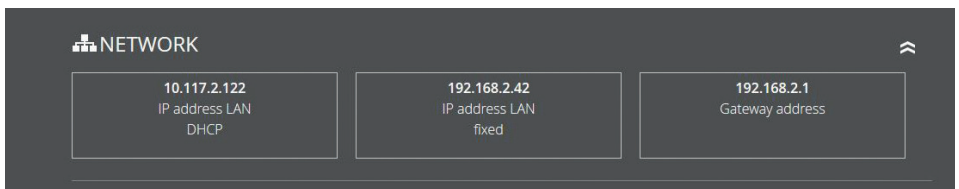

Fig. 155: Network

The IP address DHCP, IP address LAN fixed and gateway address are indicated in this area.

### 7.2.10.2 Change password

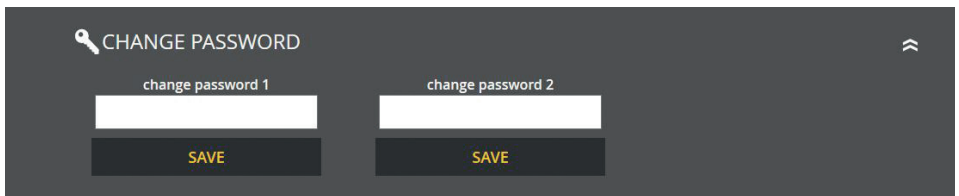

Fig. 156: Change password

Any password on hand can be changed here. For this, you need to preselect the password required and enter the new password.

**Password 1 = Accessing the main menu (Level 1 factory settings: "0000")**  
**Password 2 = Accessing the extended settings: Test menu and system settings (Level 2 factory settings: "1234")**



Fig. 157: Mask "Devices options"

You can activate or deactivate the "Automatic continuous operating test" on this level.

### 7.2.10.3 E-mail settings

The screenshot displays the 'E-MAIL SETTINGS' configuration page. It features a grid of six panels, each for a different recipient address (1 through 6). Each panel includes a text input field for the recipient address, a section for 'Messages to Email Address' with five checkboxes, and a 'SAVE' button. The checkboxes are: 'Mains operation', 'Function test', 'Operating test', 'Consumers faulty', and 'at least 3 Consumers faulty'. The interface is dark-themed with white text and yellow 'SAVE' buttons.

Fig. 158: E-mail settings

Twelve e-mail addresses can be entered here. A setting can be made for each recipient entered as to the e-mails of which messages are to be sent to the recipient.

**The following messages can be selected:**

- Mains failure
- Function test
- Operating test
- Faulty consumer
- At least 3 consumers are faulty
- Invert relay function

### 7.2.10.4 E-mail access data

**E-MAIL ACCESS DATA**

Recipient-Addresses

User name:

Email address:

SMTP port:

SMTP server:

SMTP password:

Coding:

**SAVE**

Fig. 159: Access data E-mail

You can enter the access data and passwords here.

## 7.2.11 Building visualisation

Activating building visualisation presents you with the emergency lighting in the building. Visualisation provides the user with a rapid overview of all consumers connected to the SAFELOG device and of the SAFELOG device itself. You can - at any time - glance over the status of the system and consumers and immediately react in the event of a failure. Building visualisation also helps users (including those from outside) to quickly orientate themselves within the building.

**To make use of building visualisation you need a building layout plan (as jpg or png) in which the SAFELOG device and consumers are placed. Application is optimised for the Firefox browser. Problems may arise in depicting a number of functions in other browsers.**

### 7.2.11.1 Setting up building visualisation

Setting up building visualisation is as follows:

- Designation of the building layout plan
- Selection of the building layout plan wanted
- Upload the layout plan (JPG or PNG format)

The screenshot shows a web interface titled "OVERVIEW - BUILDING LAYOUT PLANS". At the top, there are navigation tabs: "Description", "Status", "Info", "Location", and "Option". Below the tabs, there is a section titled "Upload the new building layout plan" with a sub-note: "Please note that JPG and PNG are the permitted file formats and that a file must be no larger than 2 MB". A white text input field is present, followed by a "Browse ..." button and the text "No file selected". At the bottom of the form is a large black button with the word "UPLOAD" in yellow capital letters.

Fig. 160: Building layout plan - upload

A building layout plan can be added through the "Manage building layout plans" menu item. For this, a name is entered for the plan and then the building layout plan is selected through the "Look through" function in the directory. The name and plan are accepted with the "Upload" button. This is followed by the building layout plan being shown in the overview. Consumers can now be assigned (see Chapter "Operating") and plans deleted here.

### 7.2.11.2 Operating

With the "Look at, assign/edit consumers" menu item you can assign consumers and their locations to a building layout plan.

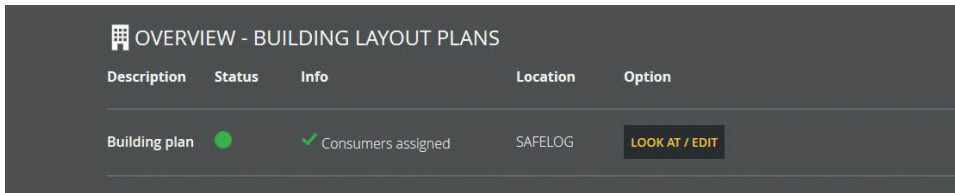

Fig. 161: Look at, assign/edit consumers

Shown in the building layout plan overview of this menu item are the description, status, information on assigned consumers, location and the editing options.

These editing options allow you to assign consumers to the building layout plan (if not already undertaken), edit the consumer assignment and look at the building layout plan. A new page on which the selected plan is indicated and can be edited is loaded for these options.

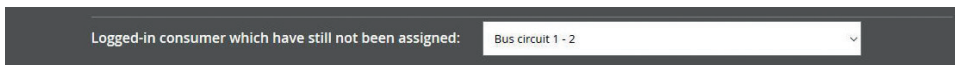

Fig. 162: Assign/edit consumers

Consumers not as yet assigned are selected in the upper area and positioned with a mouse click on the building layout plan.

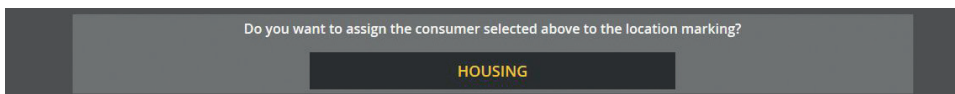

Fig. 163: Confirm allocation

Confirmation is then needed for the selected assignment. This then results in the consumers being indicated on the building layout plan. In addition, all assigned consumers are listed underneath the building layout plan. Location markings can be cleared there.

**Assigned consumer:**

Bus circuit 1 - 1 [Clear the assignment](#)

Bus circuit 1 - 2 [Clear the assignment](#)

Fig. 164: Clear assigning

### 7.2.11.3 Specimen plan

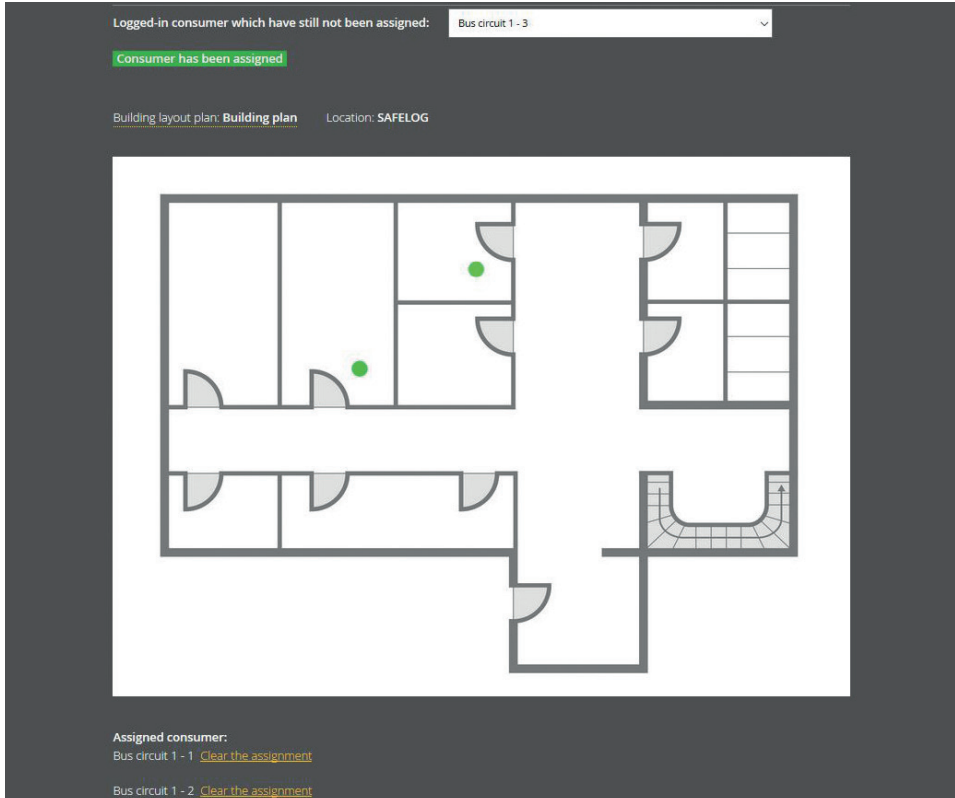

Fig. 165: Specimen plan

Figure 165 displays a specimen plan with two assigned consumers and the location marking of the SAFELOG device. The assigned consumers are shown underneath the building layout plan. They can be cleared here. The consumers are coloured as in the status display (see Chapter "Elements detailed view", "Status display").

The corresponding consumer location is shown as soon as you point the mouse over a consumer on the plan. To this end, the consumer location needs to be entered in the SAFELOG device. Otherwise only the circuit assignment appears.

## 8. Maintenance of the System

The SAFELOG device is to be tested on the basis of the nationally valid regulations and provisions. The following details claim to be complete (subject to technical modifications).

### 8.1 Initial inspections of the installation

The SAFELOG device is to be tested on the basis of the following standards once set-up and installed:

- Examination of the lighting figures, EN 1838, DIN 5035-6
- EN 50172, VDE 0100-600, VDE 0100-560, VDE 0100-718, VDE 0108-100

### 8.2 Recurrent inspections

Recurrent inspections of the electrical system are for the sake of safety. The recurrent inspections are to be carried out along the lines of the nationally valid provisions. The checks are to be logged in the test logbook of the SAFELOG device with both date of the inspection and the result. An automatic testing appliance must comply with ISO 62034.

Following an operating duration test, the battery does not have its full capacity available up to renewed charging and there is a risk of the power supply failing. Tests lasting for some appreciable time (battery duration test) are only to be carried out when risks are low or securing steps are initiated up to when battery charging is complete.

#### 8.2.1 Daily inspections

A ready-to-operate state of the system is to be ensured from a daily visual check of the devices' displays. The SAFELOG device need not be directly examined when during the operating-required time its state at a constantly monitored point is reported on (e.g. by the remote-controlled status panel MTF4):

**The following states are to be signalled:**

- System ready for use
- System in the emergency light mode
- System at fault

**8.2.2 Weekly inspections**

A switch-over to the power source is to be done on a weekly basis for safety considerations and a test made on the function of the consumers for the emergency lighting. An automatic testing appliance to be used must comply with EN 62034. Carry out a function test on the SAFELOG device display to examine the switch-over and consumers at the SAFELOG device.

**8.2.3 Monthly inspections**

The function test must include a simulation of the power supply outage of the general lighting. Every consumer of the emergency lighting is to be operated in the battery operation during the function test and every one checked for proper functioning. Power supply to the general lighting is to be restored after the inspection. Then check on operation of the monitoring unit for the SAFELOG device.

**8.2.4 Yearly inspections**

**The yearly inspection must not be automatically triggered!**

Along with the inspections under "Monthly inspections" the following ones are to be carried out every year:

The rated duration of the system (operating duration test) is to be inspected on a yearly basis. This involves the SAFELOG device examining each self-contained luminaire consumer as regards the required operating duration and it must be ensured that the consumers are present, clean and operable. The general lighting power supply needs to be

restored and the consumer charging units checked for proper functioning. The required inspection (operation duration test) is to be done on the SAFELOG device.

### **8.2.5 Inspections every three years**

Every 3 years at the latest the illuminance of the emergency lighting is to be tested on the basis of EN 1838.

## **8.3 Protocols on recurrent inspections (Test protocols)**

Recurrent test findings are to be documented in the test logbooks. The documentations are to be kept for at least 5 years. The operator of the safety unit is responsible for organizing and monitoring all the tests.

**All work on the system is to be recorded in the protocol and presented, if need be.**

## 9. Appendix

### 9.1 Fault notifications and failure correction

Given that you have problems with the SAFELOG system or the system indicates failures, you can proceed as described in the following sections according to the type of problem/failure.

#### 9.1.1 Missing consumers

The fact of consumers not being found during an automatic search can have various causes.

Using the consumer position list created during installation, you can determine which consumers have not been found by the SAFELOG system and then establish the position of these consumers.

#### **Thereupon please check the following points:**

- Does the SELF-LED light up green? If it does not: is there a problem with the mains supply of the consumers?
- Are the bus lines (including the socket on the electronics) correctly connected? If not, please correct.
- How long is the bus line? In case of lengths > 1,000 metres problems can occur. If necessary – please use – a line coupler.
- Are several consumers missing in the bus circuit? If so, the circuit is probably broken. Please check the bus line.
- Was the required topology observed? Star wiring leads to problems and must thus be avoided.

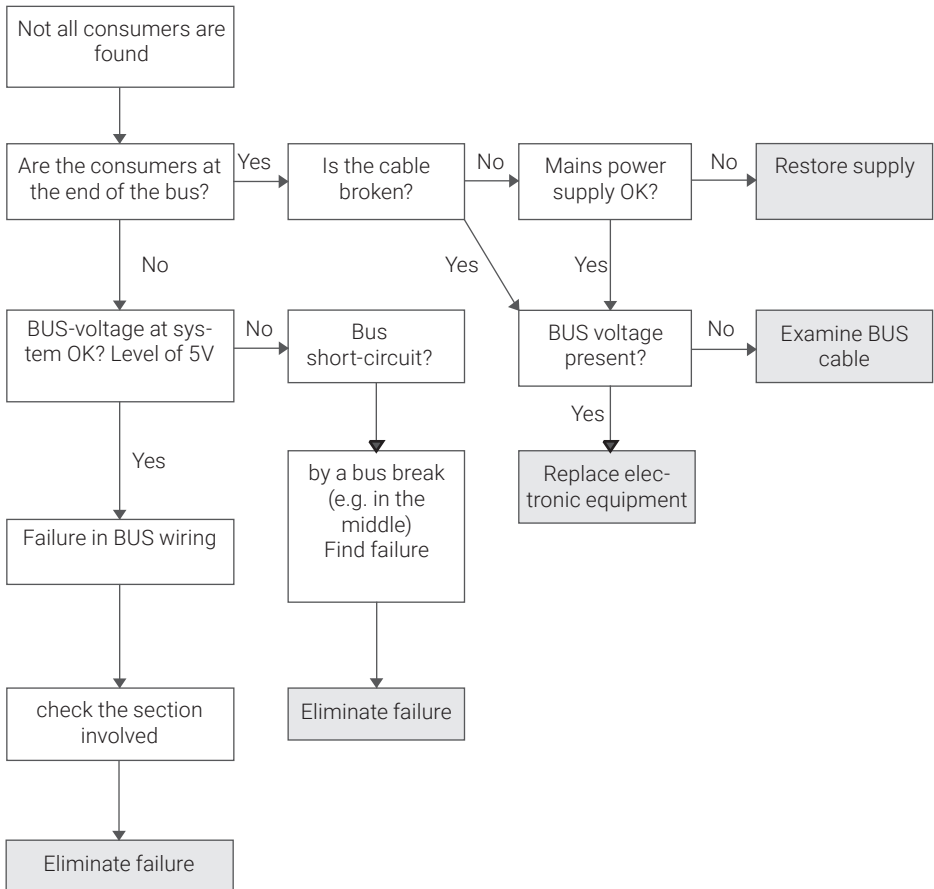

## 9.1.2 Failure messages

The SAFELOG system constantly monitors the connected consumers as to their function both constantly and within the scope of the regularly performed tests. In this context, the following failures can occur, which can in turn be eliminated as described:

Failure message	Monitoring interval	Meaning of the failure	Elimination of the failure
Accu defect	Constant	The accu has been removed or is defective.	Exchange the defective battery and then reset the electronics*.
Communication failure	Constant	Connection with the consumer has been interrupted.	Examine the bus connection at the respective consumer. Is the plug correctly inserted in the socket? Are the bus lines correctly inserted into the bus terminal?
Battery time not reached	Battery time test	The battery capacity is insufficient for the required battery time to be attained.	Exchange the consumer accu and then RESET the electronics*.
LED defect	Function test	A failure has been detected in the lighting element.	Check the connection to the LED lighting element. If the connection is OK, exchange the LED lighting element. If the lighting element works again after that, manually carry out F-test so as to reset the failure.
Battery	Constant	The mains supply of the consumer has been interrupted.	Check the mains supply line

\* A RESET of the luminaire electronics is performed by de-energising the electronics for at least 5 seconds by removing the accu and disconnecting the mains supply.

### 9.1.3 Communication failure

The SAFELOG system monitors communication with the consumers. If it is interrupted, then the failure is reported on at the SAFELOG device.

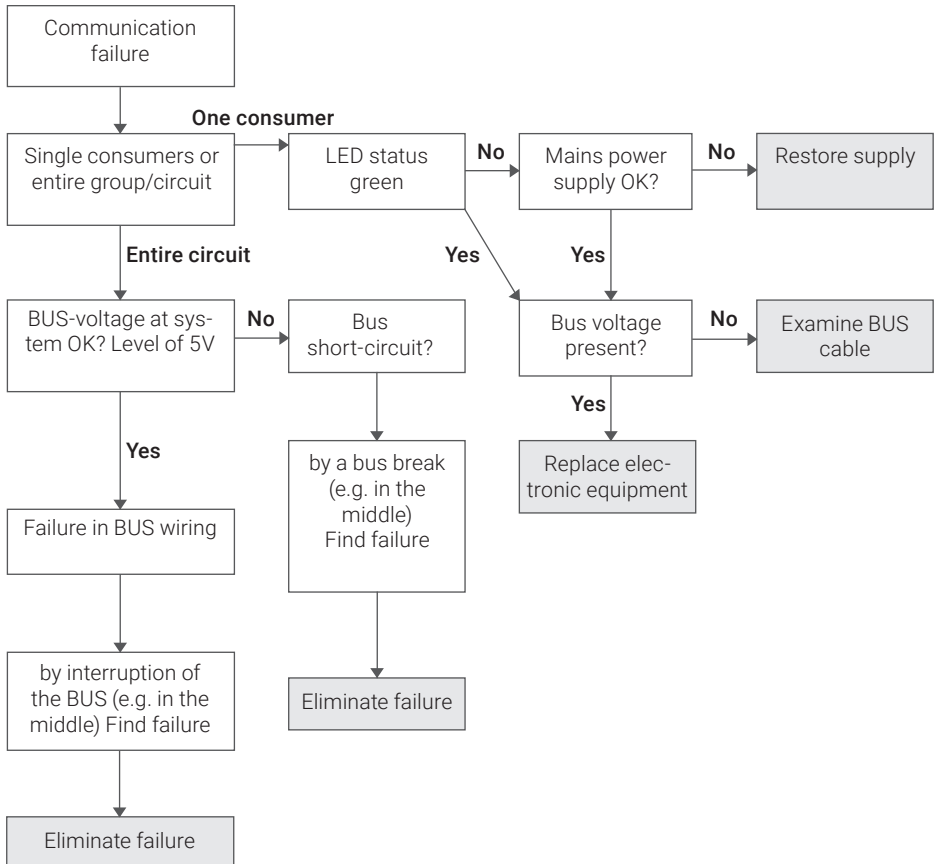

#### Communication failure following a wiring fault

Work on the BUS system of the system.

Any consumer necessitating correction of a failure at the bus system must be re-„started“.

For this, the mains power and battery supply must be disconnected.

## 9.1.4 Other failures

Failure message	Possible cause of the failure
<p>consumer does not light up even though no failure is indicated.</p>	<ol style="list-style-type: none"> <li>1. Possibly an F-test has not yet been performed which could have detected a defective illuminant. Conduct a manual F-test to check whether the failure is then reported.</li> <li>2. Is the luminaire in question a safety luminaire? All safety luminaires are delivered from the factory in non-maintained mode. As described under "Programming the switch function Non-maintained mode (NMM) / Maintained mode (MM) of the consumers", the operating mode of the consumer can be changed.</li> </ol>
<p>An exit luminaire cannot be switched to non-maintained mode by the SAFELOG system.</p>	<p>Check whether a jumper has been inserted between "L" and "L'" on the luminaire electronics and remove it, if necessary.</p>

## 9.1.5 SAFELOG device is off

If the system does not turn on, first check the mains supply. If the mains supply is OK, the internal fuse may be defective (e.g., due to overvoltage). Please contact Customer Service as soon as possible.

## 9.2 Replacing consumers

The following points must be observed in order to correct failures and retain the data specified on them (Bus circuit and consumer number):

1. The defective consumer must be cleared in the SAFELOG main control unit before its removal. In the case of several defective consumers, repeat the procedure individually.  
> Main menu: Settings / Consumer data / Bus circuit / Consumers / Clear consumer.  
Clearing the consumer ensures that the new consumer will later receive the space that has become available in the list of consumers as a result of this clearing.
2. When removing the consumers of the SAFELOG-LINE SL type, care must be taken not to create any short circuits in the bus line. In the event of short circuits, failures will be logged in the SAFELOG main control unit. They also relate to other consumers in this BUS circuit since the communication has been interfered with.
3. Since the consumers on being removed from the SAFELOG Wireless SWK have no additional bus line, Point 2 ceases to apply.
4. The new consumer can be installed after removing the defective consumer.
5. This must be followed by a consumer search in the SAFELOG main control unit: > Main menu: Settings / Consumer circuits / Search in Bus circuits / search on the single circuit or in all circuits.
6. The consumer position list should be refreshed after changing the consumer. The new consumer has a specified, unmodifiable hardware address and for this reason the new address label should be affixed over the old one in the list.
7. We recommend performing another backup of the system configuration on a USB stick after the tasks have been completed:  
> Main menu: Settings / System / Import\_Export Systemdate / Secure data.

**IMPORTANT:** A service entry shall be made in the test logbook if changes have been made to the SAFELOG system: > Main menu: Test logbook / manual documentation / Consumers serviced

## 10. Connection and Programming of the Switching inputs

### 10.1 Switching consumers via additional modules

The wiring below indicates Switch input 1 (IN1) with the 24V supply voltage for external modules

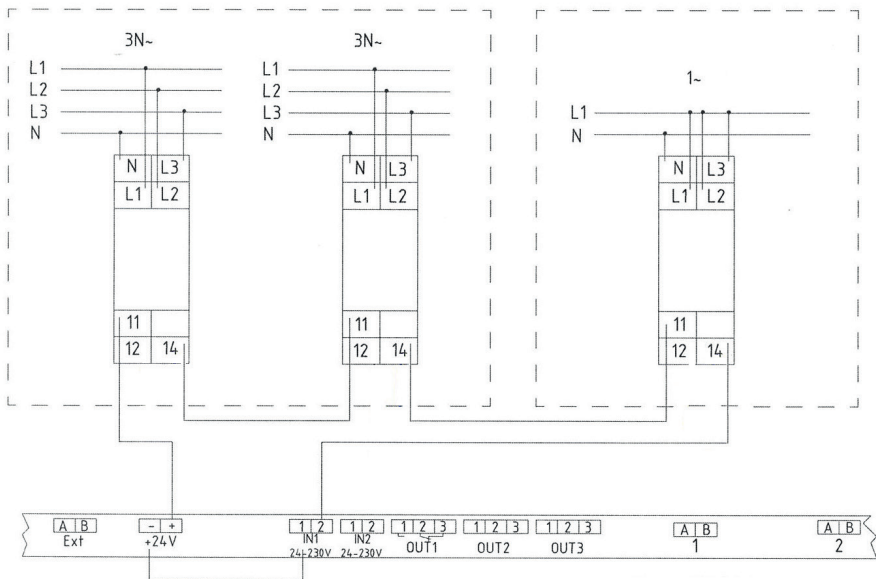

Fig. 166: Connecting additional modules

#### Setting of the system

##### Step 1:

- Establish a Group "X" (1-48) which all consumers in the non-maintained mode (NMM) must belong to.

**Do note:** On no account are any consumers in the maintained mode to belong to the group

- Now programme these consumers into the established group. (Menu item Settings / Consumer data / Selection of the functions / Groups)

**Step 2:**

- Select Control input 1 and choose the "Actuate NMM Group" function. Then enter Group "X" as chosen in Step 1. (Menu item Settings /Inputs and outputs / Digital port functions / Function Input 1).
- In addition, the "Invert function" must be selected. (Menu item Settings /Inputs and outputs / Digital port functions / Function Input 1).

**You need to simulate the mains failure function once for the programming to be adopted. Only after that is the function active.**

Absence of the signal (24V) in the mains monitor loop results in actuation of Switching input 1. All consumers of Group „X“ are switched from non-maintained mode (NMM) to maintained mode (MM).

Switching input 1 is actuated as soon as the mains monitor loop is again closed. After actuation, all consumers of Group „X“ are switched from maintained mode (MM) to non-maintained mode (NMM).

## 10.2 Switching consumers without additional modules

EN

All consumers for self-contained battery have an internal mains fault detector which on the supply voltage failing switches the consumers to the battery operation. The result is simultaneously transmitted to the SAFELOG main control unit.

The wiring below indicates Switch 1 (IN1) and Relay output 1 with the 24V supply voltage for external modules.

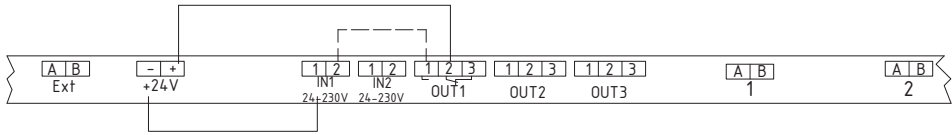

Fig. 167: Supervision / control of consumers without additional modules

## Setting of the system

### Step 1:

- Establish a Group "X" (1-48) which all consumers in the non-maintained mode (NMM) must belong to.  
**Do note:** On no account are any consumers in the maintained mode to belong to the group

- Now programme these consumers into the established group. (Menu item Settings / Consumer data / Selection of the functions / Groups)

### Step 2:

- Select Control input 1 and choose the "Actuate NMM Group" function. Then enter Group "X" as chosen in Step 1. (Menu item Settings / Inputs and outputs / Digital port functions / Function Input 1)

### Step 3:

- Select Relay output 1 and choose the "Mains failure" function. (Menu item Settings / Inputs and outputs / Relay functions / Function Relay 1)

**You need to simulate the mains failure function once for the programming to be adopted. Only after that is the function active.**

Any failure of the supply voltage (230V AC) at a consumer is transmitted to the main control unit. This unit switches Relay 1 (Relay contact 2-3 to 1-2) and sends the signal (24V) to Switch input 1.

All consumers of Group "X" are switched from non-maintained mode (NMM) to maintained mode (MM).

As soon as all consumers are supplied with voltage (230V AC), Relay 1 (Relay contact 1-2 from 2-3) switches and disconnects the signal (24V) from Switch input 1. All Group "X" consumers then switch from the maintained mode (MM) back to the non-maintained mode (NMM).

### 10.3 Connection of status panel (MFT4)

An external status panel can be connected to the SAFELOG. For this, you can use our MFT4 or an external analogue panel. Clarify the matter of using an external analogue status panel beforehand with your Service partner.

The status panel needs to be connected to the relay outputs for transmission of messages. If switching is also to be continued from the status panel, then the switch input also needs to be assigned.

#### Connection MFT4 status panel

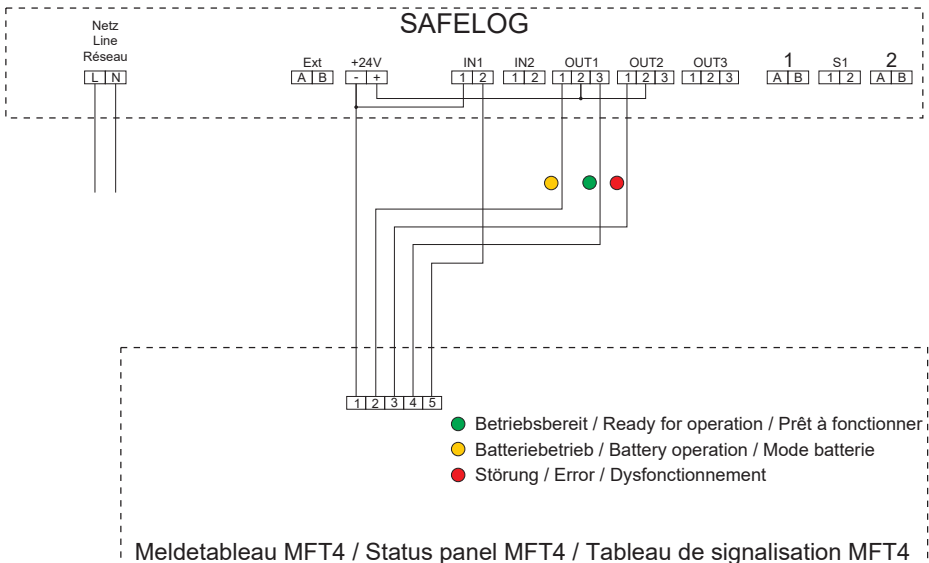

EN

Fig. 168: Connection Status panel (MFT4)

## Setting the system for the MFT4

### Step 1:

- Select Relay output 1 and choose the "Mains failure" function.  
(Menu item Settings /Inputs and outputs / Relay functions / Function Relay 1)

### Step 2:

- Select Relay output 2 and choose the "Faulty consumers" function. (Menu item Settings /Inputs and outputs / Relay functions / Function Relay 2)
- In addition, the "Invert relay function" must be selected. (Menu item Settings /Inputs and outputs / Relay functions / Function Relay 2)

### Step 3:

- Select Control input 1 and choose the "Actuate consumers" function. (Menu item Settings /Inputs and outputs / Digital port functions / Function Input 1)
- In addition, the "Invert function" must be selected.  
(Menu item Settings /Inputs and outputs / Digital port functions / Function Input 1)

**You need to simulate the status panel function once for the programming to be adopted. Only after that is the function active.**

As of: January 2021

Subject to technical modifications, mistakes, sentence errors, printing errors and printing-induced colour variations.

Item No.: 670572-V02

